



INTERNATIONAL CANOE FEDERATION

# DRAGON BOAT

COMPETITION RULES

**2025**

Deleted: 2023

Taking effect from 1 January 2025

Deleted: 2023

Deleted: 2023

# INTRODUCTION

The purpose of this document is to provide the rules that govern:

- a) Dragon Boat (including Traditional Boat)
- b) The organisation of Dragon Boat competitions

# LANGUAGE

British English is the recognised language for all communication relating to these competition rules and the conduct of all canoeing international competitions.

Any word which may imply the masculine gender also includes the feminine.

# COPYRIGHT

Copyright belongs to the ICF.

These rules may be photocopied.

The original version of this rule book can be found on the ICF website [www.canoeicf.com](http://www.canoeicf.com).

# RULES STRUCTURE

<b>ICF Sport Governance Rules</b> <ul style="list-style-type: none"><li>• Common Rules applicable to all disciplines</li><li>• Exactly the same wording contained in the first chapter of each rule book</li></ul>	[CR]
<b>ICF Principle Rules</b> <ul style="list-style-type: none"><li>• The principle is applicable to all disciplines</li><li>• Rules tailor made for each discipline</li><li>• The principle affects all NFs to a high extent</li></ul>	[PR]
<b>ICF Sport Rules</b> <ul style="list-style-type: none"><li>• Competition and Field of Play rules</li><li>• All technical aspects specific to the disciplines</li></ul>	[SR]

# RULES DECISION PROCESS

## ICF Sport Governance Rules [CR]

	Congress	Board of Directors	Technical Committee	National Federations
Proposal		X	X	X
Drafting Wording		X		
Discussion	X			
Vote	X			

## ICF Principle Rules [PR]

	Congress	Board of Directors	Technical Committee	National Federations
Proposal		X	X	X
Drafting Wording		X		
Discussion	X			
Vote	X Overall policy and direction	X Final wording after congress		

## ICF Sport Rules [SR]

	Congress	Board of Directors	Technical Committee	National Federations
Proposal			X	X
Drafting Wording			X	
Discussion		X		
Vote		X		

# PROCEDURE FOR REVIEW OF ICF RULES

The year prior to the Congress	<b>May to November</b>	Consultation with all stakeholders (e.g., athletes, coaches, officials) about rule changes needed.
	<b>December to First (1<sup>st</sup>) of March</b>	Rule proposals by National Federations and ICF Technical Committees.
The year of the Congress	<b>March</b>	Analysis of all proposals by ICF Technical Committees.
	First (1 <sup>st</sup> ) ICF Board of Directors meeting in <b>March / April</b>	Vote of the sport rules [SR]. Assessment of sport governance rules [CR] and principle rules [PR].
	At least three (3) months prior to the Congress	Publication of the approved sport rules [SR] by the ICF Board of Directors. Publication of the assessed sport governance rules [CR] and principle rules [PR].
	ICF Congress <b>November / December</b>	Vote of the sport governance rules [CR]. Vote of the main policies and directions concerning the principle rules [PR].
	Board of Directors meeting after the Congress <b>November / December</b>	Vote of the principle rules [PR].
	<b>First (1<sup>st</sup>) of January</b> After the Congress	Publication and application of the approved rule changes.

Deleted: 2023

# GLOSSARY

<b>Sport</b>	The sport is canoeing, kayaking and all paddling activities.
<b>National Federation</b>	Member National Federation of the International Canoe Federation.
<b>Discipline</b>	A discipline is a branch of a sport comprising one (1) or several events (e.g., Canoe Sprint, Canoe Slalom...).
<b>Competition</b>	The competition runs from the start of the first event to the completion of the last event of a discipline, excluding the Opening and Closing Ceremonies.
<b>Athlete or player</b>	Male or female athlete. In Canoe Polo refer to a player.
<b>Gender</b>	Men or Women
<b>Boat/board</b>	A boat/board is the watercraft used to practice canoeing (e.g., canoe, kayak, SUP): <ul style="list-style-type: none"> <li>• A single boat/board: a boat/board with only one (1) place for an athlete (e.g. kayak single);</li> <li>• A crew boat/board: a boat/board with more than one (1) place for an athlete (e.g. canoe four).</li> </ul>
<b>Age group</b>	e.g., junior, under 21, under 23, masters depending on each discipline
<b>Category</b>	A category is defined by a boat/board and a gender (e.g., Men Kayak, Mixed Canoe).
<b>Class</b>	A class is defined by a category and the number of places in a boat/board (e.g., men kayak double; women canoe four).

<b>Event</b>	An event is a contest in one (1) discipline resulting in the award of medals. An event is defined by at least a class and depending on the competition and the discipline with the additional optional information: a distance and / or an age group (e.g., junior men's kayak double 500m, under 23 women's kayak single, men's canoe double classic).
<b>Type of event</b>	<ul style="list-style-type: none"> <li>• <b>Individual events:</b> A boat/board comprised of one (1) or more athletes competing against other boats/boards.</li> <li>• <b>Team events:</b> two (2) or more boats/boards competing together against other teams.</li> </ul>
<b>Event Phase</b>	A stage of competition (e.g., preliminaries, heats, semifinal, final).
<b><u>Groups</u></b>	<u>Denoting one section (usually 5-10 athletes) that paddles in reverse ranked sequence for each run in a phase.</u>
<b>Run or race or match</b>	The basic unit of an event phase (e.g., heats 1 <sup>st</sup> run, semifinal, final).
<b>Competition programme</b>	The list of events included in a competition.
<b>Competition schedule</b>	The complete list of events and their different phases with the time at which they will be held.
<b>International Technical Official</b>	Oversee the operation of the competition.
<b>Host Organising Committee</b>	The host organising committee can be a National Federation or a subsidiary or a third party organisation specialising in competition management.
<b>Definition of meaning</b>	<ul style="list-style-type: none"> <li>• may: optional</li> <li>• should: recommendation</li> <li>• must: mandatory / compulsory</li> </ul>

Deleted: 2023

<b>Sport Class (only paracanoe book)</b>	A Sport Class is a category defined by ICF Paracanoe in the Classification Rules, in which Athletes are grouped by reference to the impact of an eligible impairment on their ability to execute the specific tasks and activities fundamental to the sport.
--	--



# LIST OF ABBREVIATIONS

ICF	International Canoe Federation
NF	National Federation
DBC	Dragon Boat Committee
ICF HQ	International Canoe Federation Headquarters
CR	Sport Governance Rules
PR	Principle Rules
SR	Sport Rules
HOC	Host Organising Committee
ITO	International Technical Official
DNS	Did Not Start
DSQ	Disqualified for the event
DNF	Did Not Finish
DQB	Disqualified for the whole competition for Unsportsmanlike Behaviour
WADA	World Anti-Doping Agency

# TABLE OF CONTENTS

<b>CHAPTER 1 - SPORT GOVERNANCE</b> .....	<b>12</b>
1.1 - International competitions [CR] .....	12
1.2 - International competition calendar [CR] .....	12
1.3 - Athlete eligibility for ICF competition (level 1 to 3) [CR] .....	13
1.4 - Age group [CR] .....	14
1.5 - Athlete sporting nationality change [CR] .....	14
1.6 - Entries process [CR] .....	15
1.7 - Validity of a competition [CR] .....	17
1.8 - ICF World Championships (level 1) [CR] .....	18
1.9 - Masters World Championships (level 4) [CR] .....	19
1.10 - Anti-doping [CR] .....	19
1.11 - Appeal to the ICF Board of Directors [CR] .....	20
1.12 - Disqualification for serious unsportsmanlike behaviour [CR] .....	20
1.13 - Results [CR] .....	21
1.14 - Trademarks and advertising [CR] .....	21
1.15 - International Technical Official (ITO) - examination [CR] .....	22
1.16 - ITO - nomination for ICF competitions [CR] .....	23
<b>CHAPTER 2 - INTRODUCTION</b> .....	<b>24</b>
2.1 - Objective [PR] .....	24
2.2 - International competitions [PR] .....	24
<b>CHAPTER 3 - ATHLETE EQUIPMENT</b> .....	<b>25</b>
3.1 - Boats specifications [PR] .....	25
3.2 - Construction [PR] .....	25
3.3 - Requirements for international Dragon Boat competitions [SR] .....	25
3.4 - The paddle [PR] .....	26
3.5 - Identifications and Advertising Trademarks [PR] .....	26
<b>CHAPTER 4 - COMPETITION PROGRAMME</b> .....	<b>27</b>
4.1 - Boats and distances [PR] .....	27
4.2 - Events [PR] .....	28
4.3 - Composition of the crew [SR] .....	30
<b>CHAPTER 5 - COMPETITION FORMAT</b> .....	<b>32</b>
5.1 - Heats and finals [SR] .....	32
<b>CHAPTER 6 - INVITATIONS AND ENTRIES</b> .....	<b>33</b>
6.1 - Invitations [PR] .....	33
6.2 - Entries [PR] .....	33
<b>CHAPTER 7 - COMPETITION OFFICIALS</b> .....	<b>34</b>
7.1 - Competition officials [SR] .....	34
7.2 - Duties of the Competition Committee [SR] .....	35
7.3 - Duties of the Officials [SR] .....	36
<b>CHAPTER 8 - FIELD OF PLAY</b> .....	<b>41</b>
8.1 - course / technical instalations [SR] .....	41
8.2 - Layout [SR] .....	41
8.3 - Course for 2000m races [SR] .....	42
<b>CHAPTER 9 - PRE-COMPETITION</b> .....	<b>43</b>
9.1 - Duties of the Host Organising Committee [SR] .....	43
9.2 - Team Leader [PR] .....	43
9.3 - Instructions for Team Leaders and athletes [PR] .....	43
9.4 - Team Leaders Meeting [PR] .....	44
9.5 - Alteration of entries and withdrawals [PR] .....	44
9.6 - Alteration to the order of events [PR] .....	44
9.7 - Boat and paddle control [SR] .....	44

<b>CHAPTER 10 - COMPETITION .....</b>	<b>45</b>
10.1 - Means of propulsion [SR] .....	45
10.2 - Boarding [SR] .....	45
10.3 - Start [SR] .....	45
10.4 - Paddling on the course [SR] .....	47
Paddle on courses up to 500m [SR] .....	47
10.5 - Paddling on the course for 2000 meters pursuit race: [SR] .....	48
10.6 - Interruption [SR] .....	48
10.7 - External assistance [SR] .....	49
10.8 - Finish [SR] .....	49
10.9 - Warnings [SR] .....	50
10.10 - Disqualifications [PR] .....	50
<b>CHAPTER 11 - POST-COMPETITION .....</b>	<b>52</b>
11.1 - Protest [PR] .....	52
11.2 - Results and reports [PR] .....	52
<b>CHAPTER 12 - WORLD CHAMPIONSHIPS .....</b>	<b>53</b>
12.1 - Organisation [PR] .....	53
12.2 - Competition Programme [PR] .....	53
12.3 - Invitations, entries and competition schedule [PR] .....	54
12.4 - System of division and progression [PR] .....	55
12.5 - Competition committee and officials [PR] .....	56
12.6 - Photo-finish and timekeeping [SR] .....	57
12.7 - Appeal to the Jury [PR] .....	57
12.8 - Awards [PR] .....	57
12.9 - Nations cup ranking [PR] .....	58
<b>CHAPTER 13 - WORLD CUP .....</b>	<b>59</b>
13.1 - Organisation [PR] .....	59
13.2 - Competition programme [PR] .....	59
<b>CHAPTER 14 - ITO - TRAINING PATHWAY .....</b>	<b>60</b>
14.1 - Examination [PR] .....	60
<b><i>I - 8-SEATER BOAT .....</i></b>	<b>66</b>
<b><i>II - 10-SEATER BOAT .....</i></b>	<b>66</b>
<b><i>III - 20-SEATER BOAT .....</i></b>	<b>67</b>

# CHAPTER 1 - SPORT GOVERNANCE

## 1.1 - INTERNATIONAL COMPETITIONS

[CR]

1.1.1 - All competitions announced as international must be governed by the rules of the ICF.

1.1.2 - Competitions organised by a National Federation, or its affiliated associations are regarded as international if foreign athletes / teams are invited.

1.1.3 - Canoeing competitions in regional, continental, and multi-sport Games must be organised under the ICF rules for World Championships for that discipline.

1.1.4 - The organisation and programme of canoeing in multi-sport games on a world level must be approved by the ICF and for continental level by the relevant continental association.

**Deleted:** <#>The Olympic events should be used as a base for the competition programme in continental games.¶

## 1.2 - INTERNATIONAL COMPETITION CALENDAR [CR]

1.2.1 - The international competition calendar of each discipline is organised in four (4) levels:

	Type of competition	Competition
Level 1	ICF competition	ICF World Championships
Level 2		ICF World Cups
Level 3		ICF World Ranking competitions
Level 4	<ul style="list-style-type: none"><li>• International competitions</li><li>• Masters or open competitions</li><li>• Invitational competitions</li></ul>	

1.2.2 - Only a National Federation, associate member, their clubs, or a continental association of the ICF may apply for a competition level 4 to be entered into the ICF calendar.

1.2.3 - A calendar application for an international competition level 1 and level 2 is outlined in the ICF statutes.

**Deleted:** 2023

1.2.4 - A calendar application for an international competition level 3 (if applicable) and level 4 can be made by the following process:

1.2.4.a - A calendar application is made directly into the ICF database;

1.2.4.b - The deadline for calendar applications for international competition level 3 is First (1<sup>st</sup>) of September the year before the competition;

1.2.4.c - The deadline for calendar applications for international competition level 4 is three (3) months before the competition.

1.2.5 - Calendar publication

1.2.5.a - The calendar of ICF competitions level 1 and level 2 will be published by 1<sup>st</sup> January the year before the competitions;

1.2.5.b - The calendar of ICF competitions level 3 will be published by First (1<sup>st</sup>) of October the year before the competitions;

1.2.5.c - The calendar of international competitions (level 4) will be published immediately after approval by the ICF.

### **1.3 - ATHLETE ELIGIBILITY FOR ICF COMPETITION (LEVEL 1 TO 3) [CR]**

1.3.1 - Only athletes who are members of clubs or associations affiliated with a National Federation have the right to participate in an ICF competition.

1.3.2 - An athlete having satisfied 1.3.1. and having first obtained the (written) consent of the athlete's National Federation, is permitted to compete individually in an ICF competition.

1.3.3 - Each National Federation must ensure that their athletes are in a good state of health and fitness which allows them to compete at a level commensurate with the level of the particular ICF competition.

1.3.4 - Each National Federation must ensure that their athletes, team officials, as well as the National Federation itself, carry appropriate health, accident, and personal belongings insurance.

## 1.4 - AGE GROUP

[CR]

1.4.1 - The first year an athlete can compete in an ICF competition (level 1 to 3) or an international competition (level 4) is the year of their 15<sup>th</sup> birthday.

1.4.2 - An athlete starting from the year of their 13<sup>th</sup> birthday can compete in an international competition (level 4) in a specific age group event with a suitably adapted competition format / rules defined by the HOC.

1.4.3 - The last year an athlete can compete in the U16 age group is the year of their 16<sup>th</sup> birthday.

1.4.4 - The last year an athlete can compete in the junior age group is the year of their 18<sup>th</sup> birthday.

1.4.5 - The last year an athlete can compete in the under 21 age group is the year of their 21<sup>st</sup> birthday.

1.4.6 - The last year an athlete can compete in the under 23 age group is the year of their 23<sup>rd</sup> birthday.

1.4.7 - An athlete can compete in a masters' event in the year that they reach the lower limit of the age group. The masters' age groups are defined by each discipline with a minimum age of 35 years.

1.4.8 - To enter in an event with a specified age group an athlete or the National Federation must produce documentary proof such as passport, identity card or similar document with a photograph, confirming the age of the athlete.

## 1.5 - ATHLETE SPORTING NATIONALITY CHANGE [CR]

1.5.1 - An athlete who has competed internationally at any level in the last three (3) years requires authorisation from the ICF with the approval of the two (2) National Federations involved to change sporting nationality.

1.5.2 - For an athlete to be eligible for a change of sporting nationality he/she must have lived in that country for the last one (1) year or hold the nationality of the new country.

1.5.3 - An athlete who is aged 18 or under can change sporting nationality with the approval of the two (2) National Federations involved. He/she is not required to fulfil the one (1) year residency rule.

Deleted: 2023

1.5.4 - The request for the change of sporting nationality must be made to the ICF by the new National Federation no later than 30<sup>th</sup> of November the year before the athlete wants to compete.

1.5.5 - For the Olympic and Paralympic Games, the Olympic and Paralympic Charter rules will be applied for nationality issues.

1.5.6 - For an athlete to gain an Olympic or Paralympic quota place in canoeing they must hold citizenship/nationality of the National Federation they represent.

1.5.7 - An athlete cannot compete for more than one (1) National Federation in any calendar year in canoeing.

1.5.8 - UN Refugee athlete.

1.5.8.a - An athlete that has no recognised country of sporting nationality and has official UN Refugee status can compete in ICF competitions. The request to compete in ICF Competitions must be sent to the ICF Headquarters who will decide if the entry can be accepted in conjunction with the Technical Chair of the discipline;

1.5.8.b - The Refugee athlete will hold the same status as a national team member from other countries in the ICF competition and abide by ICF Statutes and Competition Rules;

1.5.8.c - The Refugee athlete must be allowed to compete in the National Championships in the country where he/she obtained UN Refugee status;

1.5.8.d - Changes to the athletes UN Refugee status or that the athlete obtains a sporting nationality will activate the ICF rules for sporting nationality.

## 1.6 - ENTRIES PROCESS

[CR]

1.6.1 - ICF competitions (level 1 to level 3).

1.6.1.a - Nominal entries for ICF competitions will only be accepted from National Federations which are current members of the ICF;

#### 1.6.1.b - An entry must contain:

- Name of the National Federation to which the athlete(s) belongs;
- First and last name for the athlete(s);
- The country of birth of the athlete(s);
- The gender of the athlete(s);
- Date of birth of the athlete(s);
- The ICF number of the athlete(s) (if known);
- The events in which the athlete(s) or team(s) wish to take part;
- The first, last name(s) and the e-mail address of the Team Leader.

1.6.1.c - Nominal entries must be made on the ICF online entry system;

1.6.1.d - A receipt for the nominal entry will be available via the ICF online entry system;

1.6.1.e - The deadline for nominal entries is 10 days before the first day of competition or classification for paracanoe;

1.6.1.f - In extraordinary circumstances, an application can be made to the Technical Chair for the acceptance of late nominal entries from National Federations. It is the Technical Chair's discretion to accept or decline a late entry. Late entries to the competition will incur a fee of 50 euros per athlete in addition to the participation fee (late entries and withdrawals from events are described in chapter 13);

1.6.1.g - In crew boats the names of the athletes must be in the order that they compete in the boat. The first name must be the athlete at the front of the boat.

#### 1.6.2 - International competition (level 4).

1.6.2.a - Nominal entries for international competitions (level 4) will be accepted from individuals or National Federations;

1.6.2.b - Entries must be in writing or online in accordance with the regulations given by the HOC;



1.6.2.c - An entry must contain:

- The sporting nationality of the athlete;
- First and last name(s) for the athlete;
- The gender of the athlete;
- Date of birth of the athlete;
- The events in which the athlete(s) or teams wish to take part.

1.6.2.d - The HOC must acknowledge in writing or electronically the receipt of each entry within two (2) days.

## 1.7 - VALIDITY OF A COMPETITION

[CR]

1.7.1 - World Championships (ICF competition level 1).

1.7.1.a - In the Olympic and Paralympic events, a valid World Championship is held only if at least six (6) National Federations from at least three (3) continents start in the event. If during the competition some National Federations drop out or do not finish, the validity of the Championships is not affected;

1.7.1.b - For the non-Olympic and non-Paralympic events, a valid World Championship is held only if at least six (6) National Federations in each event and at least three (3) continents start OVERALL in the competition. If during the competition some National Federations drop out or do not finish, the validity of the Championships is not affected.

1.7.2 - World Cup (ICF competition level 2) and ICF competition level 3:

1.7.2.a - A valid World Cup is held only when there is a minimum of five (5) National Federations from at least two (2) continents start in the competition;

1.7.2.b - To be recognised as a valid event at least three (3) boats/boards or three (3) teams from two (2) different National Federations start in that event;

1.7.2.c - For the validity of the event it is not necessary for all three (3) boats/boards or all three (3) teams finish.

1.7.3 - To be recognised as an international competition (level 4) at least an invitation must be distributed to National Federations or to foreign athletes.

## 1.8 - ICF WORLD CHAMPIONSHIPS (LEVEL 1) [CR]

1.8.1 - World Championships are only organised upon the authority of the ICF Board of Directors and only in the events given in the competition programme.

1.8.2 - Changes to the organisation of the World Championships may only be made by the process documented in the contract between the ICF and the HOC.

1.8.3 - The ICF Board of Directors will determine the competition programme, based on the recommendation of the concerned Technical Committee.

1.8.4 - The competition schedule is the responsibility of the ICF. The ICF will consider the broadcasting needs and / or other external factors affecting the schedule.

1.8.5 - Jury.

1.8.5.a - During the World Championships, the supreme authority rests with the Jury;

1.8.5.b - The Jury consists of three (3) persons;

1.8.5.c - The ICF Board of Directors appoints the members of the Jury;

1.8.5.d - One (1) of these members is named Chair of the Jury.

1.8.6 - Awards.

1.8.6.a - The awards are given according to the ICF protocol guidelines;

1.8.6.b - The medals are awarded as follows:

- 1<sup>st</sup> place: a gold medal
- 2<sup>nd</sup> place: a silver medal
- 3<sup>rd</sup> place: a bronze medal

1.8.6.c - In the crew boat/board events or team events, each athlete will receive the appropriate medal;

Deleted: 2023

1.8.6.d - To maintain the formality of the ceremony the athletes receiving medals must wear their national team uniforms.

1.8.6.e Athletes/crews/teams who only have an invalid result mark (IRM), are not awarded.

1.8.6.f In case of a crew change in crew boats during the competition, medals will be awarded only to the athletes who competed in the last phase of the competition.

## 1.8.7 - Nations Cup.

1.8.7.a - The Nations Cup will be awarded to the National Federation at the World Championships with the best overall performance;

1.8.7.b - The ranking list will be produced according to the system defined for each discipline.

## 1.9 - MASTERS WORLD CHAMPIONSHIPS (LEVEL 4) [CR]

1.9.1 - Masters World Championships can be organised in each discipline.

1.9.2 - The ICF Board of Directors will determine the events based on the recommendations of the concerned Technical Committee.

1.9.3 - Individual and National Federations entries will be accepted.

## 1.10 - ANTI-DOPING [CR]

1.10.1 - Doping as defined in the World Anti-Doping Code and the ICF anti-doping rules is strictly forbidden.

1.10.2 - The anti-doping programme must be conducted in accordance with the ICF anti-doping control regulations under the supervision of the ICF medical and anti-doping committee.

1.10.3 - Athletes and support personnel, entered in any ICF competition or continental championships must complete the ICF's anti-doping education programme or equivalent before competing or risk being denied entry to the competition.

Formatted: Heading 5

Deleted: 2023

## 1.11 - APPEAL TO THE ICF BOARD OF DIRECTORS [CR]

1.11.1 - A participating National Federation can appeal to the ICF Board of Directors if, after the end of the competition, new facts become known that would substantially affect a decision made at the competition.

1.11.2 - Matters of fact considered during the competition cannot be contested in an appeal.

1.11.3 - An appeal to the ICF Board of Directors must be submitted within 30 days following the end of the competition accompanied by a fee of 75 Euros. The fee will be refunded if the appeal is upheld.

1.11.4 - The ICF Board of Directors makes its decision and addresses it in writing to the National Federation.

## 1.12 - DISQUALIFICATION FOR SERIOUS UNSPORTSMANLIKE BEHAVIOUR [CR]

1.12.1 - "Disqualified for Serious Unsportsmanlike Behaviour (DQB)" indicates a disqualification due to a serious breach of the applicable rules or regulations issued by the ICF or the governing body responsible for the competition, or a violation of the World Anti-Doping Code.

1.12.2 - For DQB, the ICF has complete discretion regarding whether an Athlete/Team will be disqualified from one, several or all of the events entered at the competition, regardless of whether they are scheduled, in progress or already completed.

1.12.3 - For disqualification after competition caused by doping or ineligibility the following must be completed:

- Deletion of all achieved results and rankings of boat(s) /board(s) (DQB);
- Re-calculation of all results accordingly;
- Production of the revised version of all affected outputs (results, summaries, medals).

## 1.13 - RESULTS

[CR]

1.13.1 - For ICF competitions (level 1 to 3) an electronic copy of the detailed official results must be provided to the ICF in a specified format within seven (7) days of the end of the competition. Electronic results must be kept online for historical purposes.

1.13.2 - For international competitions (level 4) an electronic copy of the detailed entries and official results should be sent to the ICF in pdf format for publication on the ICF website within seven (7) days of the end of the competition.

## 1.14 - TRADEMARKS AND ADVERTISING

[CR]

1.14.1 - The advertising of tobacco smoking and strong spirit drinks is not permitted.

1.14.2 - Boats/boards, accessories and clothing may carry trademarks, advertising symbols and written text.

1.14.3 - Images, symbols, slogans and written text unrelated to sport funding or any political messages are not permitted.

1.14.4 - All advertising materials used should be placed in such a way that they do not interfere with athletes' identification and do not affect the outcome of the race.

## 1.15 - INTERNATIONAL TECHNICAL OFFICIAL (ITO) - EXAMINATION [CR]

### 1.15.1 - Examination calendar.

1.15.1.a - Each year the calendar of official examinations is published for each discipline following proposal from each Technical Chair;

1.15.1.b - Continental associations or National Federations are entitled to apply to hold an examination to the concerned Technical Chair. In this case, this organising entity has to cover the examination organisation costs including the full board and travelling expenses of the examiners.

### 1.15.2 - Candidates' application.

1.15.2.a - Only National Federations are entitled to nominate candidates for examination at least 30 days before the examination;

1.15.2.b - The applications must be sent to the ICF headquarters on the form designed by the ICF and published on the ICF website;

1.15.2.c - The ICF headquarters will forward the list of candidates to the concerned Technical Chair;

1.15.2.d - For every candidate applying for the examination, the National Federation will be charged 20 euros;

1.15.2.e - The final invoice will be sent to the National Federation in the period between 30<sup>th</sup> of October and 30<sup>th</sup> of November;

1.15.2.f - National Federations are financially responsible for their Officials.

### 1.15.3 - Conduct of the examination.

1.15.3.a - A sub-committee, appointed by the concerned Technical Chair, will administer the examination;

1.15.3.b - The examination will be carried out in English for officials who wish to be considered as officials for ICF competitions and will be based on their knowledge of the ICF statutes and the ICF rules. Each discipline may add a practical assessment or minimum experience requirement;

1.15.3.c - If candidates take the examination in any other official language, they may not be considered for officiating at ICF competitions.

#### 1.15.4 - Officials' card

1.15.4.a - After completion of the examination the concerned Technical Chair completes the ICF official examination report and sends it to the ICF headquarters, where the officials' cards for those who passed the exam are issued and sent to the National Federations;

1.15.4.b - The officials' cards expire after four (4) years;

1.15.4.c - If an official's card is expired, lost, or destroyed a 20 euro fee for renewal will be charged;

1.15.4.d - A renewed official's card will be issued starting from the previous expiry date;

1.15.4.e - If an official's card has been expired for more than two years, the ITO must complete the examination again.

### 1.16 - ITO - NOMINATION FOR ICF COMPETITIONS [CR]

1.16.1 - Only National Federations are entitled to nominate ITOs for ICF competitions level 1 and level 2.

1.16.2 - The deadline for submitting ITO proposals for each discipline is the 31<sup>st</sup> of December the year prior to the competition.

1.16.3 - The nominations are submitted to the respective Technical Chair (with a copy to the ICF headquarters).

1.16.4 - The Technical Chair will present a list of Officials to the ICF Board of Directors for their approval at the latest by 1<sup>st</sup> of March.

Deleted: 2023

## CHAPTER 2 - INTRODUCTION

### 2.1 - OBJECTIVE

[PR]

The aim of a Dragon Boat competition is for competitors to race each other in Dragon Boats over a clearly defined unobstructed course in the shortest possible time according to the rules.

### 2.2 - INTERNATIONAL COMPETITIONS

[PR]

#### 2.2.1 - Types of international competitions:

Type of Competition		Competition	Entries
ICF competition	LEVEL 1	ICF World Championships ICF Junior and U23 World Championships	1 boat per event per NF
	LEVEL 2	ICF Club Crews World Championships	1 boat per club, 5 clubs per event per NF
		ICF World Cups	To be determined by the organiser
LEVEL 3			
International competition	LEVEL 4	International competitions Masters or open competitions Invitational competitions	

2.2.2 - These competitions must be supervised or managed by at least one (1) accredited official in possession of a valid ICF Dragon Boat Official card.



## CHAPTER 3 - ATHLETE EQUIPMENT

### 3.1 - BOATS SPECIFICATIONS

[PR]

Boats	<u>8-seater class</u>	10-seater Small class	20-seater Standard class
Length* (cm)	<u>780</u>	<u>900</u>	<u>1240</u>
Width** (cm)	<u>100</u>	<u>103</u>	<u>115</u>
Height*** (cm)	<u>45</u>	<u>49</u>	<u>53</u>
Min. weight**** (kg)	<u>135</u>	<u>135</u>	<u>245</u>

Note:

\* Without head and tail

\*\* measured from the outer margin

\*\*\* measured from the middle of the boat

\*\*\*\* The minimum weight does not include the drum, drum chair, steering paddle, dragon head and dragon tail.

Formatted Table

Deleted: 965

Deleted: 9

Deleted: 16

Deleted: 6

Deleted: 55

Deleted: 5

Deleted: 40

Deleted: 50

### 3.2 - CONSTRUCTION

[PR]

3.2.1 - Modifications regarding the dimensions and shape of the Dragon Boat are not allowed.

3.2.2 - The “ICF Standard Class” and the “ICF Small Class” boat exists as a one-piece and two-piece version.

3.2.3 - A Dragon Boat in principle has a Dragonhead, a Dragon tail, a drum, and a drum chair. Exemptions due to technical reasons of the racecourse and use of traditional boats, must be applied for by writing to the ICF Dragon Boat Committee and approved at least four (4) weeks prior to the start of the competition.

3.2.4 - The ICF provides a Technical Specification Sheet of the Dragon Boat (see Appendix 2).

### 3.3 - REQUIREMENTS FOR INTERNATIONAL DRAGON BOAT COMPETITIONS

[SR]

3.3.1 - The HOC must provide two (2) boats for each lane established at the racecourse and two (2) substitute boats.

3.3.2 - The HOC must take care and guarantees, that the same type of boat are provided for all crews and the difference of weight between the boats utilised in a race may not exceed three (3) %.

Deleted: 2023

3.3.3 - For international competitions, traditional boats other than ICF classes are allowed.

3.3.4 - The HOC has to take care that sufficient repair material for the Dragon Boats in the boat pool.

### **3.4 - THE PADDLE [PR]**

3.4.1 - All paddles must meet the ICF requirements provided in the Technical Specification Sheet for the paddle (Appendix 3).

3.4.2 - The length of the paddle must be between minimum of 105cm and maximum of 130cm.

3.4.3 - The paddles can be made from any materials.

3.4.4 - Snatch bands and edge protection made of adhesive tape are allowed.

### **3.5 - IDENTIFICATIONS AND ADVERTISING TRADEMARKS [PR]**

Requirements for advertising on equipment and clothing for ICF Dragon Boat competitions are detailed in the ICF Guidelines for Advertising Trademark Identification on Equipment Manual.

# CHAPTER 4 - COMPETITION PROGRAMME

## 4.1 - BOATS AND DISTANCES

[PR]

4.1.1 - The official boats recognised by the ICF are the following: 10-seater and 20-seater.

4.1.2 - The official distances recognised by the ICF are: 200m, 500m and 2000m. The 2000 meters must be conducted as a pursuit race and achieved in the 500 meters racecourse by three (3) turns over two (2) laps.

### 4.1.3 - Categories

The official categories recognised by the ICF are the following:

#### 4.1.3.a 10-seater boat

Open	Women	Mixed
Junior	Junior	Junior
Senior	Senior	Senior
Master 40+	Master 40+	Master 40+
Master 50+	Master 50+	Master 50+

#### 4.1.3.b 20-seater boat

Open	Women	Mixed
Senior	Senior	Senior
Master 40+	Master 40+	Master 40+

#### 4.1.3.c 8-seater boat

Open	Women	Mixed
Junior	Junior	Junior
Senior	Senior	Senior
Master 40+	Master 40+	Master 40+
Master 50+	Master 50+	Master 50+

Formatted: Font: 14,5 pt, Bold

Formatted: Font: Bold

Formatted: Font: 14,5 pt, Bold

Formatted: Font: Bold

Formatted: Font: 14,5 pt, Bold

Formatted: Font: Bold

Formatted: No Spacing, Centred

Formatted Table

Formatted: Font: 14,5 pt

Formatted: Font: 14,5 pt

Formatted: Font: 14,5 pt

Formatted: No Spacing, Centred

Formatted: Font: 14,5 pt

Formatted: Font: 14,5 pt

Formatted: Font: 14,5 pt

Formatted: No Spacing, Centred

Formatted: Font: 14,5 pt

Formatted: No Spacing, Centred

Formatted: Font: 14,5 pt

Formatted: Font: 14,5 pt

Formatted: Font: 14,5 pt

Formatted: Font: 14,5 pt

Formatted: Font: 14,5 pt

Formatted: No Spacing, Centred

Formatted: Font: 14,5 pt

Formatted: Font: 14,5 pt

Formatted: Font: 14,5 pt

Formatted: No Spacing

Formatted Table

Formatted: Font: 14,5 pt

Formatted: Font: 14,5 pt

Formatted: Font: 14,5 pt

Formatted: No Spacing

Formatted: Font: 14,5 pt

Formatted: Font: 14,5 pt

Formatted: Font: 14,5 pt

Formatted: No Spacing

Formatted Table

Deleted: 2023

4.1.4 - Special events may be organised after approval and under the supervision of the ICF DBC.

## 4.2 - EVENTS [PR]

The ICF Dragonboat events are:

Open	Women	Mixed
<u>8-seater 200m</u>	<u>8-seater 200m</u>	<u>8-seater 200m</u>
10-Seater 200m	10-Seater 200m	10-Seater 200m
20-Seater 200m	20-Seater 200m	20-Seater 200m
<u>8-seater 500m</u>	<u>8-seater 500m</u>	<u>8-seater 500m</u>
10-Seater 500m	10-Seater 500m	10-Seater 500m
20-Seater 500m	20-Seater 500m	20-Seater 500m
<u>8-seater 2000m</u>	<u>8-seater 2000m</u>	<u>8-seater 2000m</u>
10-Seater 2000m	10-Seater 2000m	10-Seater 2000m
20-Seater 2000m	20-Seater 2000m	20-Seater 2000m

For Junior age group the events are:

Open	Women	Mixed
<u>8-seater 200m</u>	<u>8-seater 200m</u>	<u>8-seater 200m</u>
10-Seater 200m	10-Seater 200m	10-Seater 200m
<u>8-seater 500m</u>	<u>8-seater 500m</u>	<u>8-seater 500m</u>
10-Seater 500m	10-Seater 500m	10-Seater 500m
<u>8-seater 2000m</u>	<u>8-seater 2000m</u>	<u>8-seater 2000m</u>
10-Seater 2000m	10-Seater 2000m	10-Seater 2000m

- Formatted ... [1]
- Formatted ... [4]
- Formatted ... [5]
- Formatted ... [6]
- Formatted ... [2]
- Formatted Table ... [3]
- Formatted ... [7]
- Formatted ... [10]
- Formatted ... [11]
- Formatted ... [8]
- Formatted Table ... [9]
- Formatted ... [12]
- Formatted ... [13]
- Formatted ... [14]
- Formatted ... [15]
- Formatted ... [16]
- Formatted ... [19]
- Formatted ... [20]
- Formatted ... [17]
- Formatted Table ... [18]
- Formatted ... [21]
- Formatted ... [23]
- Formatted ... [25]
- Formatted ... [22]
- Formatted ... [24]
- Formatted ... [26]
- Formatted ... [27]
- Formatted Table ... [28]
- Formatted ... [29]
- Formatted ... [30]
- Formatted ... [31]
- Formatted ... [33]
- Formatted ... [34]
- Formatted ... [32]
- Formatted ... [35]
- Formatted ... [38]
- Formatted ... [39]
- Formatted ... [40]
- Formatted ... [36]
- Formatted Table ... [37]
- Formatted ... [41]
- Formatted ... [44]
- Formatted ... [45]
- Formatted ... [42]
- Formatted Table ... [43]
- Formatted ... [46]
- Formatted ... [49]
- Formatted ... [50]
- Formatted ... [47]
- Formatted Table ... [48]
- Formatted ... [51]
- Formatted ... [54]
- Formatted ... [55]
- Formatted ... [52]

For Masters 40+ age group the events are:

Open	Women	Mixed
<u>8-seater 200m</u>	<u>8-seater 200m</u>	<u>8-seater 200m</u>
10-Seater 200m	10-Seater 200m	10-Seater 200m
20-Seater 200m	20-Seater 200m	20-Seater 200m
<u>8-seater 500m</u>	<u>8-seater 500m</u>	<u>8-seater 500m</u>
10-Seater 500m	10-Seater 500m	10-Seater 500m
20-Seater 500m	20-Seater 500m	20-Seater 500m
<u>8-seater 2000m</u>	<u>8-seater 2000m</u>	<u>8-seater 2000m</u>
10-Seater 2000m	10-Seater 2000m	10-Seater 2000m
20-Seater 2000m	20-Seater 2000m	20-Seater 2000m

For Masters 50+ age group the events are:

Open	Women	Mixed
<u>8-seater 200m</u>	<u>8-seater 200m</u>	<u>8-seater 200m</u>
10-Seater 200m	10-Seater 200m	10-Seater 200m
<u>8-seater 500m</u>	<u>8-seater 500m</u>	<u>8-seater 500m</u>
10-Seater 500m	10-Seater 500m	10-Seater 500m
<u>8-seater 2000m</u>	<u>8-seater 2000m</u>	<u>8-seater 2000m</u>
10-Seater 2000m	10-Seater 2000m	10-Seater 2000m

- Formatted ... [56]
- Formatted ... [59]
- Formatted ... [60]
- Formatted ... [61]
- Formatted ... [57]
- Formatted Table ... [58]
- Formatted ... [62]
- Formatted ... [65]
- Formatted ... [66]
- Formatted ... [63]
- Formatted Table ... [64]
- Formatted ... [67]
- Formatted ... [68]
- Formatted ... [69]
- Formatted ... [70]
- Formatted ... [71]
- Formatted ... [74]
- Formatted ... [75]
- Formatted ... [72]
- Formatted Table ... [73]
- Formatted ... [76]
- Formatted ... [78]
- Formatted ... [80]
- Formatted ... [77]
- Formatted ... [79]
- Formatted ... [81]
- Formatted ... [82]
- Formatted Table ... [83]
- Formatted ... [84]
- Formatted ... [85]
- Formatted ... [86]
- Formatted ... [88]
- Formatted ... [89]
- Formatted ... [87]
- Formatted ... [90]
- Formatted ... [93]
- Formatted ... [94]
- Formatted ... [91]
- Formatted Table ... [92]
- Formatted ... [95]
- Formatted ... [98]
- Formatted ... [99]
- Formatted ... [96]
- Formatted Table ... [97]
- Formatted ... [100]
- Formatted ... [103]
- Formatted ... [104]
- Formatted ... [101]
- Formatted Table ... [102]
- Formatted ... [105]
- Formatted ... [108]
- Formatted ... [109]
- Formatted ... [106]
- Formatted Table ... [107]

## 4.3 - COMPOSITION OF THE CREW

[SR]

4.3.1 - A Dragon Boat crew of boats with 20 paddlers is composed of:

- Paddlers (minimum 18, maximum 20);
- A drummer;
- A steerer;
- Four (4) substitute paddlers in the respective classes.

4.3.2 - A Dragon Boat crew of boats with 10 paddlers is composed of:

- Paddlers (minimum eight (8), maximum 10);
- A drummer;
- A steerer;
- Two (2) substitute paddlers in the respective classes.

4.3.3 - A Dragon Boat crew of boats with 8 paddlers is composed of:

- Paddler eight (8);
- A drummer;
- A steerer;
- Two (2) substitute paddlers in the respective classes;

4.3.4 - The open crew can be composed of both male and female athletes.

4.3.5 - The women crews can only be composed of female athletes. See exceptions in articles 4.3.8 and 4.3.9.

4.3.6 - Mixed crews must include a minimum number of eight (8) and a maximum of ten (10) paddlers of either gender (boat with 20 paddlers), a minimum of four (4) and a maximum of five (5) paddlers of either gender (boat with 10 paddlers) or a minimum of three (3) and a maximum of four (4) paddlers of either gender (boat with 8 paddlers). See exceptions in articles 4.3.8 and 4.3.9.

4.3.7 - In the age category of Masters, all members of the crew must have reached the respective Masters age. See exceptions in articles 4.3.8 and 4.3.9.

**Formatted:** List Paragraph, Bulleted + Level: 1 + Aligned at: 0,63 cm + Indent at: 1,27 cm

**Deleted:** 7

**Deleted:** 8

**Deleted:** women (boat with 20 paddlers) or four (4) women (boat with 10 paddlers) respectively

**Deleted:** 7

**Deleted:** 8

**Deleted:** 7

**Deleted:** 8

**Deleted:** 2023

4.3.8 - The first year a drummer can compete is the year of their 15<sup>th</sup> birthday. The drummer can be different gender or age of the respective category.

4.3.9 - The first year a steerer can compete is the year of their 18<sup>th</sup> birthday. The steerer can be different gender or age of the respective category.

4.3.10 - An athlete may not compete for more than one (1) Club in Club Crew World Championships.

## CHAPTER 5 - COMPETITION FORMAT

### 5.1 - HEATS AND FINALS

[SR]

#### 5.1.1 - For races up to 500 meters:

5.1.1.a - The division of the boats into heats should be determined by drawing lots or by ICF World Ranking. The system of heats and the progressions are defined in Appendix 1;

5.1.1.b - B final will only be held when there are more than 18 boats in that particular event and a C final will only be held when there are more than 25 boats in that particular event;

5.1.1.c - The course must be straight and in one (1) direction;

5.1.1.d - There must be at least six (6) lanes.

#### 5.1.2 - For 2000 meters it is a pursuit race where the boats start one (1) by one (1) at same time intervals between each-other:

5.1.2.a - The course is circular with movement direction “anticlockwise”;

5.1.2.b - It should be two (2) turning points: one (1) - in finish line zone, and the other - in 500m mark zone;

5.1.2.c - The Start and the Finish of the race should be in front of the Finish Tower.



## CHAPTER 6 - INVITATIONS AND ENTRIES

### 6.1 - INVITATIONS

[PR]

6.1.1 - Invitations should be sent a minimum of two (2) months before the competition.

6.1.2 - Invitations to an international competition must contain the following information:

6.1.2.a - Date and place of the competition;

6.1.2.b - Situation and plan of the course(s);

6.1.2.c - Proposed events;

6.1.2.d - Competition programme;

6.1.2.e - Minimum depth of water;

6.1.2.f - Conditions/terms of participation;

6.1.2.g - Address to which entries should be sent;

6.1.2.h - Entries deadline.

### 6.2 - ENTRIES

[PR]

6.2.1 - Details of the entries process and forms are described in article 1.6.

6.2.2 - Similar details should be provided for the reserves, if any.

6.2.3 - In addition to nominated crews, participating NFs are allowed to enter four (4) substitutes for 20-seater and two (2) substitutes for 10-seater.

6.2.4 - When making the entries, NFs must give the colours of the clothing worn by the athletes and these colours must not be changed during the competition.

6.2.5 - The Host Organising Committee (HOC) will accept the entries in conformity with the conditions/terms of participation. Therefore, the HOC can reject or delete the entry of the participants who fail to observe the conditions/terms of participation.

6.2.6 - The entry is valid only if the payment of the entry fee is received before the deadline.

Deleted: 2023

## CHAPTER 7 - COMPETITION OFFICIALS

### 7.1 - COMPETITION OFFICIALS

[SR]

7.1.1 - International competitions are to be supervised by the following International Technical Officials (ITOs):

- Chief Official
- Deputy Chief Official
- Technical Organiser
- Competition Manager
- Boat Measurer(s)
- Boat Marshal(s)
- Starter(s)
- Aligner(s)
- Course Umpire(s)
- Turning Point Umpire(s)
- Finish Line Judge(s)
- Timekeeper(s)
- Announcer
- Medical officer

7.1.2 - If circumstances permit, one (1) person may function in more than one (1) of the above positions.

7.1.3 - Officials' obligations:

7.1.3.a - To perform their tasks in conformity with the ICF rules;

7.1.3.b - Every judge will have the obligation to check their equipment necessary to perform their tasks is in working order. In the case any shortcoming is found, it is reported to the Chief Official or Competition Manager;

7.1.3.c - Unauthorised persons must not enter any Officials area, unless are called for by either the Competition Committee or the Jury.

7.1.4 - All communications between the Competition Officials and the athletes and team leaders must be in English language. In the case of a translated being needed, must be provided by the team.

## 7.2 - DUTIES OF THE COMPETITION COMMITTEE [SR]

7.2.1 - ICF competitions are to be managed by a Competition Committee consisting of:

7.2.1.a - Chief Official

7.2.1.b - Competition Manager

7.2.1.c - One (1) additional person

7.2.2 - The additional person, may be is one (1) of the officials listed in 7.1.1, providing their duty at or near the finishing line. This person is appointed by the Competition Manager.

7.2.3 - Minimum two (2) members of the Competition Committee must be in possession of a valid International Dragon Boat Official card.

7.2.4 - The **Competition Committee** will:

7.2.4.a - Direct and supervise the competition;

7.2.4.b - Postpone the competition and decide on another time when it may be held in the event of inclement weather or other unforeseen circumstances, which make it impossible to carry out the competition;

7.2.4.c - Decide on matters concerning disqualification in cases where the rules have been broken during the competition;

7.2.4.d - Hear any protests that may be made and settle any disputes that may arise;

7.2.4.e - Make decisions based on the ICF Dragon Boat Rules;

7.2.4.f - Penalties in accordance with the ICF Statutes may also be imposed;

7.2.4.g - Hear the opinion of the Umpire who controlled the race in which the infraction was said to have occurred before any decision is made regarding an alleged infraction of the rules.

7.2.5 - A member of the Competition Committee may not participate in a judgment connected with an incident directly involving or a disqualification of an athlete from his/her own NF.

## 7.3 - DUTIES OF THE OFFICIALS

[SR]

7.3.1 - The **Chief Official**, who is also the Chair of the Competition Committee, will:

7.3.1.a - Decide on all matters arising during the actual competition, which are not dealt with in these rules;

7.3.1.b - Appoint the key positions for the officials prior to the competition.

7.3.2 - The **Deputy Chief Official**

7.3.2.a - Cooperate with the Chief Official and the Competition Manager;

7.3.2.b - Substitutes the Chief Official where necessary;

7.3.2.c - Handle the administrative tasks of the competition including but not limited to:

- Collect the forms necessary for the administration of the competition;
- Maintain a written record of the decisions of the Competition Committee passed relating to any protests and is responsible to have it recorded;
- Check the personal identification documents of the athletes and their age if necessary;
- Keep in contact with the responsible IT person in case of computer data processing;
- Check the results race by race during the competition and prepare the list of the boats qualified in the next phase of the competition.

7.3.3 - The **Technical Organiser** will deal with the complete technical electronic equipment of the Regatta-Course (automatic start system / photo finish system/ timing system / scoreboard / radio connections / boat traffic before and during the races / boat checking, etc.).

7.3.4 - The **Competition Manager** will:

7.3.4.a - Keep in constant contact with the organisers to solve any problems arising;

7.3.4.b - Supervise the races and is responsible for ensuring that the competition schedule is followed without unnecessary delay;

Deleted: 2023

7.3.4.c - Complete the competition administration for the races. (Competition schedule, drawings, results, technical documents, boat control, press, protests, etc.);

7.3.4.d - Ensure that the announcer gives all necessary information about the races such as the start order, the name of any crews failing to start and the results.

#### 7.3.5 - The **Boat Measurer(s)** will:

7.3.5.a - Assist the Technical Organiser prior to the start of the competition to test the boats taking part in the races;

7.3.5.b - Exclude from the competition any of the boats that do not fulfil the ICF rules concerning classification;

7.3.5.c - Oversee that the boats are in proper condition during the competition and conduct the boat and paddle control during the competition.

#### 7.3.6 - The **Boat Marshal(s)** will:

7.3.6.a - Divide the crews into the respective boats and announce the race lanes;

7.3.6.b - Ensure that the teams are directed to enter the boat and leave the pontoons at latest at the end of the deadline prior to the start of the respective race as fixed on the day prior to the competition by the Competition Committee and published officially to the Team Leaders.

#### 7.3.7 - The **Starter(s)** will:

7.3.7.a - Decide all matters concerning the start of the races;

7.3.7.b - Be solely responsible for false start decisions;

7.3.7.c - Ensure that the starting equipment is in working order;

7.3.7.d - Communicate with the Competition Committee before each race. After having received a signal from them that all is ready, order the boats to their places;

7.3.7.e - Utilise English in all communications with athletes, plus other languages if possible and deemed appropriate in the circumstances;

7.3.7.f - Carry out the start according to the racing rules;

7.3.7.g - Ensure that the circumstances at the start are free from any hindrance.

All decisions of the Starter are final.

#### 7.3.8 - The **Aligner(s)** will:

7.3.8.a - Bring the boats to the start line with the least possible delay;

7.3.8.b - Check the uniformity of the athletes including their attire and the boat numbers;

7.3.8.c - Utilise English in all communications with athletes;

7.3.8.d - Raise a white flag to signify to the Starter that the boats are in position to start, when they are all aligned and/or completely inside the starting boats;

7.3.8.e - Raise a red flag if the boats are not aligned and/or not in the starting boats.

#### 7.3.9 - The **Course Umpire(s)** will:

7.3.9.a - Follow the 200m and 500m races in a motorboat. The races should be accompanied by two (2) Course Umpires in two (2) separate motorboats (preferable catamaran type boats);

7.3.9.b - Ensure that during a race the rules are complied with;

7.3.9.c - Stop the competition. He/she passes all boats in the race whilst waving the red flag or using a sound signal until all boats have stopped paddling, in case of hindrances. He/she reports immediately the infraction to the Competition Committee. After that all boats should return to the start;

7.3.9.d - Show a white flag after the race has completed if there is no infraction of the rules to report;

7.3.9.e - Show a red flag and a lane number after the race has completed if there is an infraction of the rules to report;

7.3.9.f - Report immediately the infraction to the Competition Committee if the rules are broken;

7.3.9.g - Present a written report to the Competition Committee within 10 minutes in such a case.

**7.3.10 - Turning Point Umpire(s) will:**

7.3.10.a - Be stationed at every turning point. One (1) or more Umpires and one (1) recorder are used when a race is run along a course with one (1) or more turning points. They should be positioned where they gain the best view of the turn;

7.3.10.b - See the boats turn according to the rules. The recorder will make a list of all who pass the turning point;

7.3.10.c - Report immediately after the race has completed to the Competition Committee which boat has turned and if any infraction of the rules had taken place.

**7.3.11 - Finish Line Judges will:**

7.3.11.a - Be placed in a position where all lanes at the finish line can be clearly seen;

7.3.11.b - Time each race with at least two (2) stopwatches. When the stopwatches have not recorded the same time, the slowest time will be taken as correct. The stopwatches are to be started when the electronic or optical signal from the start is received;

7.3.11.c - Decide the order in which the boats have crossed the finish line when there is no Photo Finish System;

7.3.11.d - Use a simple majority to decide a dispute in the absence of a Photo Finish System and where the Finish Line Judges differ regarding determining the places of two (2) or more boats. In the case of equal voting, the Chief Judge has the casting vote;

7.3.11.e - Determine the results and compare them with the photo finish results if there is a Photo Finish System. The photo finish will be decisive.

7.3.12 - The **Timekeepers** one (1) of which will be appointed as **Chief Timekeeper**, who will:

7.3.12.a - Ensure that the timing equipment is working correctly. He/she may divide the work amongst the Timekeepers;

7.3.12.b - Compare the official times with the other Finish Line Judges at the end of each race and immediately inform the Deputy Chief Judge on them;

7.3.12.c - Timekeepers may also officiate as Finish Line Judges.

7.3.13 - The **Announcer** will:

7.3.13.a - Announce the start of each race, the order of starting and the placing of the crews during the race on the instructions of the Competition Manager;

7.3.13.b - Announce the results after the race is completed.

7.3.14 - The **Medical Officer** will:

7.3.14.a - Supervise the Anti-Doping procedures during the competitions;

7.3.14.b - Be responsible for medical matters occurring during the competitions.



## CHAPTER 8 - FIELD OF PLAY

### 8.1 - COURSE / TECHNICAL INSTALATIONS [SR]

8.1.1 - The HOC must take care that all technical installations required by the Competition Committee are available and serviceable.

### 8.2 - LAYOUT [SR]

8.2.1 - The racecourse and its installations must be checked at the latest two (2) days prior to the competition by the Chief Official or a representative appointed by the ICF DBC and a member of the ICF DBC.

8.2.2 - Both the start and finish lines must be marked with red flags and red buoys at the points where lines intersect the outer limits of the course. The start and the finish lines must be at right angles to the course.

8.2.3 - For races up to 500 meters:

8.2.3.a - The course must be straight, in one direction and without obstacles;

8.2.3.b - The depth of the water in the entire course must be at least two (2) meters;

8.2.3.c - The width of the lanes must be minimum nine (9) meters and maximum 13.5 meters;

8.2.3.d - There must be minimum six (6) lanes;

8.2.3.e - Minimum of 10 meters along both sides of the course must be included.

8.2.4 - In the 200mand 500 meters races, the lanes must be marked with buoys or floats. The distance between the buoys cannot be more than 25 m.

8.2.5 - The last buoys must be marked from № one (1) to six (6) and zero (0). The numbering goes from the left to the right with the number placed on the buoy in such a way as to be clearly visible from the finish tower.

8.2.6 - The numbered buoys (white cubes with black numbers on them) should be fixed no closer than one (1) metre and no further than two (2) metres behind the finish line;

Deleted: 2023

8.2.7 - The numbered buoys must be clearly visible to the athletes and to be on the corresponding athlete's right-hand side as they pass it.

8.2.8 - There must be an automatic start machine or start pontoons with assistants to hold the boats. Alternatively, there may be cords fixed on starting pontoons for steerers to hold on before the start.

### **8.3 - COURSE FOR 2000M RACES**

**[SR]**

8.3.1 - The course should be circular with movement direction "anticlockwise".

8.3.2 - It should be two (2) turning points: one (1) - in finish line zone, and the other - in 500m mark zone.

8.3.3 - The turning points are to be marked by at least four (4) turning point buoys with flags. The flags must be diagonally divided, with one half (1/2) in red and the other half (1/2) in yellow.

8.3.4 - The Start and the Finish of the race should be in front of the Finish Tower.

## CHAPTER 9 - PRE-COMPETITION

### 9.1 - DUTIES OF THE HOST ORGANISING COMMITTEE [SR]

9.1.1 - The HOC is responsible for the preparation and running of the competition.

9.1.2 - The HOC must, in particular:

9.1.2.a - Make available a suitable venue and technical equipment conforming to the present Dragon Boat Competition Rules;

9.1.2.b - Fix the date and the competition programme in agreement with the ICF;

9.1.2.c - Draw up and distribute the competition programme including the date and time of the Team Leaders meeting. It must be distributed in advance of the competition.

### 9.2 - TEAM LEADER [PR]

9.2.1 - The Team Leader will:

9.2.1.a - Represent his/her team;

9.2.1.b - Be the main contact with the Chief Official and the HOC throughout the competition, but he/she cannot disturb their work;

9.2.1.c - Submit any changes or comments in relation to the competition;

9.2.1.d - Arrange to submit a protest or an appeal as stipulated if necessary.

### 9.3 - INSTRUCTIONS FOR TEAM LEADERS AND ATHLETES [PR]

9.3.1 - The preliminary draw should be available at the competition venue, at the latest 24 hours before the first race of the competition, giving the names and sporting nationality of the athletes and the results of the draw.

9.3.2 - Documentation should be available for each Team Leader, at least five (5) hours before the beginning of the Team Leaders meeting, containing the following information:

- Detailed information on the course and their markings;
- Detailed competition schedule;
- Time and place of the awards ceremony.

## **9.4 - TEAM LEADERS MEETING**

**[PR]**

9.4.1 - At least 12 hours before the first race of the competition, the Team Leaders Meeting is to be held.

9.4.2 - At this meeting the names of Team Leaders should be advised.

9.4.3 - The organisers will describe the racing course and all other arrangements which should be adhered to for the duration of the competition.

9.4.4 - The Chief Official will describe the competition programme and ask for any changes to the entries.

## **9.5 - ALTERATION OF ENTRIES AND WITHDRAWALS**

**[PR]**

9.5.1 - The withdrawal of an entry is considered final, and the same crew is not allowed to re-enter into the withdrew events. Entry fees will not be refunded.

9.5.2 - After the Team Leaders Meeting has finished no modifications to the final entry list including the names of the athletes and substitutes will be allowed.

9.5.3 - The composition of the crew may be chosen from the final entry list without any restrictions during the event.

## **9.6 - ALTERATION TO THE ORDER OF EVENTS**

**[PR]**

9.6.1 - The sequence of races given in the invitation, and the intervals between the races as given in the Competition Programme, are binding on the organisers.

9.6.2 - Alterations cannot be made unless the respective Team Leaders at the Team Leaders Meeting give their consent.

## **9.7 - BOAT AND PADDLE CONTROL**

**[SR]**

The boat and paddle control must be conducted by the Boat Measurer as mentioned in the list of officials prior to the competition. Only equipment approved by this official may be used in the competition.

## CHAPTER 10 - COMPETITION

### 10.1 - MEANS OF PROPULSION

[SR]

10.1.1 - Dragon Boats must be propelled solely by means of a single-bladed paddle.

10.1.2 - The paddles must not be attached to the boat in any way except the rudder-paddle at the helm of the boat.

10.1.3 - A Dragon Boat must be paddled in a sitting position.

### 10.2 - BOARDING

[SR]

10.2.1 - After the call of the Chief Boat Marshal and 20 minutes prior to the official starting time the team must notify the Chief Boat Marshal.

10.2.2 - After this timeline each team must stand prepared for attendance and ID control by the Boat Marshal.

10.2.3 - The steerer has the duty to check in the Marshalling area prior to the race the rudder paddle and the helm of the boat. Damages of these must be reported to the Chief Boat Marshal.

10.2.4 - The athletes in each team must wear same uniform.

### 10.3 - START

[SR]

10.3.1 - Each crew must arrive at least five (5) minutes prior to the starting time in the range of vision and earshot of the Starter. On his/her instructions must bring the boat to the starting position.

10.3.2 - During roll call by the Starter the respective steerer must raise his/her hand.

10.3.3 - The crews must follow the instructions of the Starter.

10.3.4 - The crews must not delay the start. If crews delay the start, they will be warned and then disqualified by the Starter.

10.3.5 - The starting command will be: "Attention - Go" (or shot or loud sound).

10.3.6 - If a crew for technical reasons is not ready for the start, the drummer must signal this by waving both arms with the drumming sticks. The Starter will decide whether to delay the start or not.

10.3.7 - Beginning to paddle prior to the start command is considered to be a false start. In principle such a race must be stopped and re-started again.

10.3.8 - In the case of a false start, the Starter must immediately give a loud buzzer sound signal. In addition, the Course Umpire boats will cross the racecourse as long as all boats have stopped.

10.3.9 - The crews must follow the Starter's instructions for a new start.

10.3.10 - Before the new start, the Starter must identify the offending crew(s) making the false start and give them a warning.

10.3.11 - In the case of a second (2<sup>nd</sup>) false start by the same crew, the boat will be disqualified (DSQ) from the race and must leave the starting area and the course immediately.

10.3.12 - Each crew can have a false start but will be disqualified if cause a second (2<sup>nd</sup>) false start in the subsequent races of the event.

10.3.13 - A proper start will be signalled by the Starter by raising a white flag.

10.3.14 - Two (2) substitute paddles may be carried and be substituted during the race.

10.3.15 - Starting phase 2000 meters pursuit race:

10.3.15.a - The starting order is as per the starting list. The division of the boats into heats should be determined by drawing lots or by ICF World Ranking;

10.3.15.b - The start number of the boat must be shown in a clearly visible place near the starting area;

10.3.15.c - The boats start at 10 seconds intervals;

10.3.15.d - If a boat does not start, its starting number will also be shown. The Starter has to count down as per the normal sequence. The next boat must start after 2 x 10 seconds intervals;

10.3.15.e - The Starter must speak in a loud voice the countdown and starts the boat all 10<sup>th</sup> seconds with a "GO" (or shot or loud sound);

10.3.15.f - If the boat already crossed the starting line with 1% to 50% of its length in the moment of the "GO"-command, the crew is penalised with 10 seconds additional time (see Appendix 4);

10.3.15.g - If the boat already crossed the starting line with more than 50% of its length in the moment of the "GO"-command, the crew is penalised with 30 seconds additional time (see Appendix 4);

10.3.15.h - If the boat already crossed the starting line with more than 100% of its length in the moment of the "GO"-command, the crew will be disqualified DSQ (see Appendix 4).

#### **10.4 - PADDLING ON THE COURSE [SR]**

10.4.1 - The Paddling on the course phase includes the passing of the racecourse from the starting line up to the reaching of the finish line.

#### **PADDLE ON COURSES UP TO 500M [SR]**

10.4.2 - The crews must keep in the centre of the lanes. The crew will be called twice and then finally be warned if a strong deviation from the course occurs. If the team does not correct the course after the final warning the respective team may be disqualified by the Competition Committee after receiving the respective report by the Course Umpire.

10.4.3 - The Competition Committee will decide in the case of collisions of two (2) or more boats during a race, the justification for a re-start and/or disqualification of one (1) or more crews. In principle every race must be finished as long as there is no danger to the participants.

10.4.4 - Distances up to 500 m a crew must conduct and finish its race in the same lane in which it started.

10.4.5 - During the race the drummer must actively beat the drum.

Deleted: 2023

## **10.5 - PADDLING ON THE COURSE FOR 2000 METERS PURSUIT RACE: [SR]**

10.5.1 - Boats can be overtaken from the left as well as from the right side.

10.5.2 - Crew causing an obstruction of the continuation of paddling of the other crew/s may be penalised with 10 seconds added to the race time by the Competition Committee after receiving the report of the Course Umpire or Turning Point Umpire.

10.5.3 - Turns in the 2000 meters pursuit race:

10.5.3.a - Boats arriving first to the turn (having the minimum advantage from another boat as following: the first pair of paddlers of the boat are on the same level as the bow of another boat or even don't see the bow of another boat) have the right to enter the turn first, regardless of if they are on the right or left position (see Appendix 5);

10.5.3.b - Boats not negotiating the turning point buoy(s) will be disqualified (DSQ);

10.5.3.c - Boats will not be disqualified for touching a turning point buoy, unless, in the opinion of the turning point umpires, an advantage over other crews has been gained;

10.5.3.d - Boats crashing into other boats and gaining an advantage may be disqualified by the Competition Committee after receiving the report of the Course Umpire or Turning Point Umpire;

10.5.3.e - A crew is eliminated (DNF) from the race if capsized and all athletes are not able to get in the boat without outside help.

10.5.4 - During the race the drummer must actively beat the drum.

## **10.6 - INTERRUPTION [SR]**

10.6.1 - The Course Umpire has the right to interrupt a correctly started race if unforeseen hindrances raised by using a red flag and strong sound signal. Athletes must immediately stop paddling and await further instructions.

Deleted: 2023



10.6.2 - The Competition Committee will decide the starting time of the new race.

## 10.7 - EXTERNAL ASSISTANCE

[SR]

10.7.1 - External assistance may not be used during a race.

10.7.2 - Pace making may not be used during a race. Pace making is the use of sound signals from the shore or other boat (e.g., megaphone, whistles).

10.7.3 - External radio connection is not allowed.

10.7.4 - An intercom connection within the boat is allowed.

10.7.5 - Any of the above infractions will result in the disqualification of the athletes concerned (DSQ).

## 10.8 - FINISH

[SR]

10.8.1 - The boat has finished the race when its dragonhead crosses the finish line with all crew members in it.

10.8.2 - The Finish Line Judges will determine the result of the competition based on the order of the boats arriving.

10.8.3 - The crossing of the finish line must be signalled by an acoustic signal.

10.8.4 - The correct race will be confirmed by the Course Umpires by raising a white flag. The incorrect race will be signalled by the red flag.

10.8.5 - If two (2) or more boats cross the finish line at the same time, they get the same classification in the final ranking. In case of a dead heat finish for any position, which determines the advance to the next phase of the competition, the following rules will apply:

10.8.5.a - Whenever there are sufficient number of lanes available in the next phase of the competitions, a drawing of lots will determine to which race these boats will advance. It is also possible to use lane number zero (0) or seven (7);

10.8.5.b - Where there are not enough lanes available there will be a re-race between the boats involved after the last race of the day, or half-day programme or drawing lots. The decision will be made by the Chief official;

10.8.5.c - In case of a dead heat in a re-race, drawing of lots will determine the outcome.

10.8.6 - The exit of the complete crew must be in the marshalling area.

## **10.9 - WARNINGS**

**[SR]**

10.9.1 - Warnings are valid for the complete event.

10.9.2 - Warnings are allocated in the case of:

10.9.2.a - Crews showing up late to the start area;

10.9.2.b - Crews leaving their lane during the race;

10.9.2.c - Crews not observing the instructions of the Officials;

10.9.2.d - Crews causing a false start;

10.9.2.e - Crews disturbing the race by unsportsmanlike or hindering behaviour;

10.9.2.f - Crews falling short of the minimum distance between two (2) boats and causing an obstruction of the continuation of paddling of other crews.

10.9.3 - A crew receiving a second warning during the same event will be disqualified (DSQ).

## **10.10 - DISQUALIFICATIONS**

**[PR]**

10.10.1 - Any athlete who attempts to compete in a race by any other than honourable means, or who breaks the racing rules, or who disregards the honourable nature of the racing rules will be disqualified from the race concerned (DSQ).

10.10.2 - At all cases mentioned in articles 10.9 and 10.10.5.

10.10.3 - All penalties or disqualifications must be confirmed by the Competition Committee in writing immediately, giving the reasons. The Team Leader of the athlete/team must acknowledge the receipt on the notice copy.

10.10.4 - Failure to deliver the copy confirmation of the disqualification to the Team Leader does not invalidate the disqualification.

10.10.5 - The Competition Committee may discipline any athlete or Official whose behaviour is detrimental to the good order and conduct of the competition. The Competition Committee may disqualify him/her for that competition.

10.10.6 - In case of disqualification of an athlete due to a doping offense (DQB) the complete crew must be disqualified.

## CHAPTER 11 - POST-COMPETITION

### 11.1 - PROTEST

[PR]

11.1.1 - A protest against the right of a crew to compete in a race must be addressed to the Chief Official and handed to the Competition Committee, not later than one (1) hour before the start of the first race of the competition.

11.1.2 - A protest made during a competition must be in written form, addressed to the Chief Official and handed to the Competition Committee.

11.1.3 - If the protest is against a decision of the Competition Committee, the protest must be received not later than 20 minutes after the decision has been published at athlete's area notice board with exact time of publication.

11.1.4 - The Competition Committee must note the time that the decision has been published at athlete's area notice board on the written disqualification.

11.1.5 - All protests must be accompanied by a fee of 75 Euros (or an equal sum in the local currency). The fee will be refunded if the protest is upheld.

11.1.6 - When a protest or a report is made against an athlete or a team, the Team Leader of the athlete/team in question should be presented the protest or report to read.

### 11.2 - RESULTS AND REPORTS

[PR]

After the ending of World Championships and all International Dragon Boat competitions, listed in the ICF Competition Calendar, two (2) copies of the results, protests and appeals must be posted by the HOC to the ICF Headquarters (ICF HQ) as well as displayed electronically on official websites.

## CHAPTER 12 - WORLD CHAMPIONSHIPS

Refer to the International Competition Rules except as amended in this Chapter.

### 12.1 - ORGANISATION

[PR]

12.1.1 - World Championships may be arranged every year with the consent of the ICF Board of Directors, at a place and time approved by it and in accordance with the ICF Dragon Boat Rules. The World Championships may be organised every even-year and Club Crew World Championships may be organised every odd-year.

12.1.2 - The races may be held on up to four (4) consecutive days.

12.1.3 - Entries for all events must be limited to one (1) team per NF at World Championships and up to five (5) clubs per NF at the Club Crew World Championships.

### 12.2 - COMPETITION PROGRAMME

[PR]

12.2.1 - World Championships are held in the race distances of 200, 500 meters and 2000 meters.

12.2.2 - World Championships and Club Crew World Championships events are:

Open	Women	Mixed
10-Seater 200m	10-Seater 200m	10-Seater 200m
20-Seater 200m	20-Seater 200m	20-Seater 200m
10-Seater 500m	10-Seater 500m	10-Seater 500m
20-Seater 500m	20-Seater 500m	20-Seater 500m
10-Seater 2000m	10-Seater 2000m	10-Seater 2000m
20-Seater 2000m	20-Seater 2000m	20-Seater 2000m

For Junior age group the events are:

Open	Women	Mixed
10-Seater 200m	10-Seater 200m	10-Seater 200m
10-Seater 500m	10-Seater 500m	10-Seater 500m
10-Seater 2000m	10-Seater 2000m	10-Seater 2000m

For Masters 40+ age group the events are:

Open	Women	Mixed
10-Seater 200m	10-Seater 200m	10-Seater 200m
20-Seater 200m	20-Seater 200m	20-Seater 200m
10-Seater 500m	10-Seater 500m	10-Seater 500m
20-Seater 500m	20-Seater 500m	20-Seater 500m
10-Seater 2000m	10-Seater 2000m	10-Seater 2000m
20-Seater 2000m	20-Seater 2000m	20-Seater 2000m

For Masters 50+ age group the events are:

Open	Women	Mixed
10-Seater 200m	10-Seater 200m	10-Seater 200m
10-Seater 500m	10-Seater 500m	10-Seater 500m
10-Seater 2000m	10-Seater 2000m	10-Seater 2000m

12.2.3 - The order of the events is adaptable by the ICF DBC.

## 12.3 - INVITATIONS, ENTRIES AND COMPETITION SCHEDULE [PR]

12.3.1 - Invitations for World Championships will be issued by the organising NF (or HOC) and must be in accordance with the ICF Rules. Invitations should be sent out at least nine (9) months before the first day of the Championships.

12.3.2 - Entries process is described in article 1.6;

12.3.2.a - The deadline for the numerical entries is 45 full days before the first day of the competition;

Deleted: 2023

12.3.2.b - The preliminary Competition Schedule must be available at least three (3) days before the Championships and contain the following details:

- The starting time of each race (heats as well as finals);
- The names and NF of the athletes in each race;
- Full instructions on the course and training arrangements.

12.3.2.c - The competition schedule must be approved by the ICF Technical Committee. The schedule can be adaptable to meet television requirements.

12.3.3 - Alterations of the events during World Championships and World Games rest within the authority of the ICF jury.

## 12.4 - SYSTEM OF DIVISION AND PROGRESSION [PR]

12.4.1 - The drawing of lots for the first races in each class must be carried out under the control of an ICF Official.

12.4.2 - The division into heats should be made in accordance with the Dragon Boat competition rules, with the following additions:

12.4.2.a - The division into heats will be based on the results of previous World Championships. The boats placed in A, B and C finals, if applicable, will automatically be seeded. The remainder will be placed into the heats by drawing of lots;

12.4.2.b - If changes at the Team Leaders Meeting result in the fact that the actual number of boats is too small for the plan used, there may be a redraw of lots for the actual number of boats and a new plan selected.

12.4.3 - In relation to the progression plan the boats from each heat go forward to the next appropriate phase of the competition. The others are eliminated.

12.4.4 - In relation to the progression plan the boats from each semifinal go forward to a final. The others are eliminated.

12.4.5 - The Competition Committee will decide which progression plan (1 or 2) will be used for the event.

12.4.6 - The distribution of lanes for, semifinals and finals is automatically determined by the results of the previous races.

12.4.7 - A semifinal will not be held if all the competing boats would reach the next phase of the competition. The lanes for the final will be determined by means of a draw from the boats that progressed.

## 12.5 - COMPETITION COMMITTEE AND OFFICIALS[PR]

12.5.1 - World Championships must be held under the direction of a Chief Official appointed by the ICF Board of Directors.

12.5.2 - During the World Championships the Competition Committee must consist of three (3) officials who must be in possession of a valid International Official Dragon Boat card. They are:

12.5.2.a - Chief Official (Technical Chair or his/her deputy from the DBC);

12.5.2.b - Deputy Chief Official (from the DBC);

12.5.2.c - Competition Manager (from the HOC).

12.5.3 - The officials (excluding the Jury and Competition Committee) to officiate at the World Championships are:

- Technical Organiser 1
- Starters 3
- Boat Marshals 3
- Aligners 2
- Course Umpires 4
- Finishing Line Judges 3
- Timekeepers 2
- Boat Measurers 2
- Medical Officer 1
- Announcer 1

12.5.4 - In the World Championships or World Games all ITOs must be recognised International Dragon Boat officials, holding a valid Dragon Boat card.



12.5.5 - Each team attending the World Championships will pay an administration fee (set by the DBC) to share the travel costs of the ITOs to officiate at the World Championships. The travel costs will be divided over all athletes equally, based on the nominal entries, so that every National Federation pays the same amount per athlete.

## **12.6 - PHOTO-FINISH AND TIMEKEEPING [SR]**

12.6.1 - At World Championships the order of the boats arriving at the finishing line will be decided with a Photo Finish System.

12.6.2 - The HOC must provide two (2) sets of Photo-Finish equipment accepted by the ICF.

## **12.7 - APPEAL TO THE JURY [PR]**

12.7.1 - Team Leaders or other NF representatives have the right to appeal to the Jury against a decision of the Competition Committee on behalf of their athletes.

12.7.2 - The appeal must be handed to the Chair of the Jury in writing with reasons, not later than 20 minutes after the decision has been published at athlete's area notice board with exact time of publication.

12.7.3 - An appeal must be accompanied by a fee of 75 Euros (or an equal sum in the local currency). The fee will be refunded if the appeal is upheld.

12.7.4 - The appeal must be heard as soon as possible. Witnesses may be called.

12.7.5 - The decision of the Jury is final.

## **12.8 - AWARDS [PR]**

12.8.1 - The medals will be awarded in accordance with article 1.8.6 and must on no account be presented to any other persons than those who have won championship races.

12.8.2 - Only medals, to the exclusion of all other prizes, are to be presented at the official ceremony.

12.8.3 - Medals should be awarded to all athletes of the respective crews, including the reserves.

## 12.9 - NATIONS CUP RANKING

[PR]

12.9.1 - Nations Cup ranking is in accordance with article 1.8.7.

12.9.2 - The ranking will be calculated with reference to the gold medals list.

12.9.3 - In case of a tie the National Federation with the highest individual position will win the cup.

## CHAPTER 13 - WORLD CUP

Refer to the International Competition Rules and special rules for World Championships except as amended in this Chapter.

### 13.1 - ORGANISATION

[PR]

13.1.1 - There are World Cup competitions, the number of these competitions and the venue are proposed by the ICF DBC and agreed by the ICF Board of Directors.

13.1.2 - On proposal from HOC, ICF DBC will decide:

13.1.2.a - If national teams and/or club crew teams can participate;

13.1.2.b - The number of team(s) per NF / Club can participate.

### 13.2 - COMPETITION PROGRAMME

[PR]

13.2.1 - On proposal from HOC, ICF DBC will decide if the World Cup events to be organised other than those for international competitions including official boats, age groups and categories.

13.2.2 - The competition schedule for the World Cup will be decided by the ICF DBC.

## CHAPTER 14 - ITO - TRAINING PATHWAY

Procedure for becoming an ICF Dragon Boat International Technical Official:

### 14.1 - EXAMINATION

[PR]

14.1.1 - Officials Examination may be organised:

14.1.1.a - At every World Championships if there is a sufficient interest;

14.1.1.b - Out-of-World Championships examinations.

14.1.2 - Application deadlines are the same as for the International Competition Calendar. The Examination Calendar is published on the same date as the International Competition Calendar.

14.1.3 - Examination Procedure

A sub-committee consisting of two (2) members, appointed by the Technical Chair, will hold this examination as per article 1.15.

## APPENDIX 1- DIVISION SYSTEMS WITH A, B AND C FINALS

### Legend:

H	= Heat
TR	= Time Race
SF	= Semifinal
BT	= by time
1-2, 1-3, 2-5...	= from first to second place, from first to third place, from second to fifth place...
1 <sup>st</sup> , 2 <sup>nd</sup> , 3 <sup>rd</sup> ...	= boat winning first place, boat winning second place, boat winning third place...
3x3 <sup>rd</sup> , 4x4 <sup>th</sup> , 4x6 <sup>th</sup> ...	= 3 boats in third places, 4 boats in fourth places, 4 boats in sixth places...
4/H1 ... L6	= 4 <sup>th</sup> place from Heat 1 will start in lane 6
The lane distribution of the boats qualified in A, B or C final will be based on their result or time achieved in the Semifinal.	

BOATS	SYS TEM	HEATS	SEMIFINALS	FINALS
6 or less	A	Time Race 1	Time Race 2	-
7 - 12	B	2 x 6 1 <sup>st</sup> -2 <sup>nd</sup> to Final 3 <sup>rd</sup> -5 <sup>th</sup> to SF rest out	1 x 6 1 <sup>st</sup> -2 <sup>nd</sup> to Final rest out	A: 1 X 6
13 - 18	C	3 x 6 1 <sup>st</sup> -4 <sup>th</sup> to SF rest out	2 x 6 1 <sup>st</sup> -3 <sup>rd</sup> to Final rest out	A: 1 X 6
19 - 24	D	4 x 6 1 <sup>st</sup> -4 <sup>th</sup> + 2x5 <sup>th</sup> BT to SF rest out	3 x 6 1 <sup>st</sup> -2 <sup>nd</sup> to Final A 3 <sup>rd</sup> -4 <sup>th</sup> to Final B rest out	A: 1 X 6 B: 1 X 6
25 - 30	E	5 x 6 1 <sup>st</sup> -4 <sup>th</sup> + 4x5 <sup>th</sup> BT to SF rest out	4 x 6 1 <sup>st</sup> + 2x2 <sup>nd</sup> BT to Final A 2x2 <sup>nd</sup> + 4x3 <sup>rd</sup> to Final B 4x4 <sup>th</sup> + 2x5 <sup>th</sup> BT to Final C	A: 1 X 6 B: 1 X 6 C: 1 X 6
31 - 36	F	6 x 6 1 <sup>st</sup> -4 <sup>th</sup> to SF rest out	4 x 6 1 <sup>st</sup> + 2x2 <sup>nd</sup> BT to Final A 2x2 <sup>nd</sup> + 4x3 <sup>rd</sup> to Final B 4x4 <sup>th</sup> + 2x5 <sup>th</sup> BT to Final C	A: 1 X 6 B: 1 X 6 C: 1 X 6

**PLAN A BOATS 1 - 6**

HEATS		HEATS	
		Time race 1	Time race 2
H			
1		1 ..... L4	1 TR1 ..... L4
2		2 ..... L3	2 TR1 ..... L3
3		3 ..... L5	3 TR1 ..... L5
4		4 ..... L2	4 TR1 ..... L2
5		5 ..... L6	5 TR1 ..... L6
6		6 ..... L1	6 TR1 ..... L1

Formatted: French (France)

The final ranking will be based on combined time from the two (2) Time races

**PLAN B BOATS 7 - 12**

HEATS			SEMIFINALS		FINALS
			Plan B1 - SF1	Plan B2 - SF1	FINAL A
H1	H2				
7.	4	3	3/H1 ... L4	3/H1 ... L3	1/H1 ... L4
8.	4	4	4/H1 ... L5	4/H1 ... L5	2/H1 ... L2
9.	5	4	5/H1 ... L6	5/H1 ... L1	1/H2 ... L3
10.	5	5	3/H2 ... L3	3/H2 ... L4	2/H2 ... L5
11.	6	5	4/H2 ... L2	4/H2 ... L2	1/SF1 ... L6
12.	6	6	5/H2 ... L1	5/H2 ... L6	2/SF1 ... L1
1 <sup>st</sup> -2 <sup>nd</sup> direct to Final 3 <sup>rd</sup> -5 <sup>th</sup> to SF rest out			1 <sup>st</sup> -2 <sup>nd</sup> to Final rest out		

**PLAN C BOATS 13 - 18**

HEATS				SEMIFINALS		FINAL
				Plan C1 - SF1	Plan C2 - SF1	FINAL A
H1	H2	H3				
13.	5	4	4	1/H1 ... L4	2/H1 ... L5	1/SF1 ... L4
14.	5	5	4	3/H1 ... L2	3/H1 ... L6	2/SF1 ... L2
15.	5	5	5	2/H2 ... L5	1/H2 ... L3	3/SF1 ... L6
16.	6	5	5	4/H2 ... L1	4/H2 ... L1	1/SF2 ... L3
17.	6	6	5	1/H3 ... L3	1/H3 ... L4	2/SF2 ... L5
18.	6	6	6	4/H3 ... L6	3/H3 ... L2	3/SF2 ... L1
				Plan C1 - SF2	Plan C2 - SF2	
				2/H1 ... L3	1/H1 ... L3	
				4/H1 ... L1	4/H1 ... L1	
				1/H2 ... L4	2/H2 ... L4	
				3/H2 ... L2	3/H2 ... L2	
				2/H3 ... L5	2/H3 ... L5	
				3/H3 ... L6	4/H3 ... L6	
1 <sup>st</sup> -4 <sup>th</sup> to SF rest out				1 <sup>st</sup> -3 <sup>rd</sup> to Final rest out		

Deleted: 2023

**PLAN D BOATS 19 - 24**

HEATS	SEMIFINALS		FINALS
	<b>Plan D1 - SF1</b>	<b>Plan D2 - SF1</b>	<b>FINAL A</b>
H1 H2 H3 H4			
19. 5 5 5 4	1/H1 ... L3	2/H1 ... L5	1/SF1 ... L3
20. 5 5 5 5	2/H2 ... L5	1/H2 ... L3	2/SF1 ... L2
21. 6 5 5 5	2/H3 ... L4	3/H3 ... L2	1/SF2 ... L4
22. 6 6 5 5	3/H4 ... L2	4/H3 ... L1	2/SF2 ... L1
23. 6 6 6 5	4/H4 ... L6	1/H4 ... L4	1/SF3 ... L5
24. 6 6 6 6	1 <sup>st</sup> next BT L1	1 <sup>st</sup> next BT L6	2/SF3 ... L6
	<b>Plan D1 - SF2</b>	<b>Plan D2 - SF2</b>	<b>FINAL B</b>
	3/H1 ... L5	3/H1 ... L5	3/SF1 ... L4
	4/H1 ... L1	3/H2 ... L2	4/SF1 ... L5
	1/H2 ... L3	4/H2 ... L1	3/SF2 ... L3
	3/H3 ... L2	1/H3 ... L3	4/SF2 ... L6
	4/H3 ... L6	2/H4 ... L4	3/SF3 ... L2
	2/H4 ... L4	4/H4 ... L6	4/SF3 ... L1
	<b>Plan D1 - SF3</b>	<b>Plan D2 - SF3</b>	
	2/H1 ... L5	4/H1 ... L1	
	3/H2 ... L2	1/H1 ... L3	
	4/H2 ... L6	2/H2 ... L4	
	1/H3 ... L3	2/H3 ... L5	
	1/H4 ... L4	3/H4 ... L2	
	2 <sup>nd</sup> next BT L1	2 <sup>nd</sup> next BT L6	
1 <sup>st</sup> -4 <sup>th</sup> + 2 x 5 <sup>th</sup> BT to SF rest out	1 <sup>st</sup> -2 <sup>nd</sup> to Final A 3 <sup>rd</sup> -4 <sup>th</sup> to Final B rest out		

Deleted: 2023

PLAN E BOATS 25 - 30

HEATS	SEMIFINALS		FINALS
	<b>Plan E1 - SF1</b>	<b>Plan E2 - SF1</b>	<b>FINAL A</b>
H H H H H 1 2 3 4 5	1/H1 ... L3 4/H2 ... L6	3/H1 ... L2 1/H2 ... L3	1/SF1 ... L3 1/SF2 ... L5
25. 5 5 5 5 5	3/H3 ... L5	4/H3 ... L1	1/SF3 ... L4
26. 6 5 5 5 5	2/H4 ... L2	2/H4 ... L4	1/SF4 ... L2
27. 6 6 5 5 5	1/H5 ... L4	2/H5 ... L5	1 <sup>st</sup> (2 <sup>nd</sup> ) BT . L1
28. 6 6 6 5 5	4 <sup>th</sup> (5 <sup>th</sup> ) BT L1	2 <sup>nd</sup> (5 <sup>th</sup> ) BT L6	2 <sup>nd</sup> (2 <sup>nd</sup> ) BT . L6
29. 6 6 6 6 5			
30. 6 6 6 6 6			
	<b>Plan E1 - SF2</b>	<b>Plan E2 - SF2</b>	<b>FINAL B</b>
	2/H1 ... L4 1/H2 ... L3 4/H3 ... L1 3/H4 ... L5 2/H5 ... L2 3 <sup>rd</sup> (5 <sup>th</sup> ) BT L6	4/H1 ... L6 2/H2 ... L4 1/H3 ... L3 3/H4 ... L5 3/H5 ... L2 4 <sup>th</sup> (5 <sup>th</sup> ) BT L1	3 <sup>rd</sup> (2 <sup>nd</sup> ) BT . L3 4 <sup>th</sup> (2 <sup>nd</sup> ) BT . L4 3/SF1 ... L1 3/SF2 ... L6 3/SF3 ... L5 3/SF4 ... L2
	<b>Plan E1 - SF3</b>	<b>Plan E2 - SF3</b>	<b>FINAL C</b>
	3/H1 ... L2 2/H2 ... L4 1/H3 ... L3 4/H4 ... L6 3/H5 ... L5 2 <sup>nd</sup> (5 <sup>th</sup> ) BT L1	1/H1 ... L3 3/H2 ... L2 2/H3 ... L4 4/H4 ... L5 4/H5 ... L1 1 <sup>st</sup> (5 <sup>th</sup> ) BT L6	4/SF1 ... L4 4/SF2 ... L3 4/SF3 ... L2 4/SF4 ... L5 1 <sup>st</sup> (5 <sup>th</sup> ) BT . L1 2 <sup>nd</sup> (5 <sup>th</sup> ) BT . L6
	<b>Plan E1 - SF4</b>	<b>Plan E2 - SF4</b>	
	4/H1 ... L5 3/H2 ... L2 2/H3 ... L4 1/H4 ... L3 4/H5 ... L1 1 <sup>st</sup> (5 <sup>th</sup> ) BT L6	2/H1 ... L5 4/H2 ... L6 3/H3 ... L2 1/H4 ... L3 1/H5 ... L4 3 <sup>rd</sup> (5 <sup>th</sup> ) BT L1	
1 <sup>st</sup> -4 <sup>th</sup> + 4x5 <sup>th</sup> BT to SF rest out	1 <sup>st</sup> + 2 x 2 <sup>nd</sup> BT to Final A 2 x 2 <sup>nd</sup> + 4 x 3 <sup>rd</sup> to Final B 4 x 4 <sup>th</sup> + 2 x 5 <sup>th</sup> BT to Final C rest out		

Deleted: 2023



PLAN F BOATS 31 - 36

HEATS							SEMIFINALS				FINALS		
H H H H H H 1 2 3 4 5 6							<b>Plan F1 - SF1</b>		<b>Plan F2 - SF1</b>		<b>FINAL A</b>		
31.	6	5	5	5	5	5	1/H1 ... L3	4/H2 ... L6	3/H1 ... L2	1/H2 ... L3	1/SF1 ... L3	1/SF2 ... L5	
32.	6	6	5	5	5	5	3/H3 ... L5	2/H4 ... L2	4/H3 ... L1	2/H4 ... L4	1/SF3 ... L4	1/SF4 ... L2	
33.	6	6	6	5	5	5	1/H5 ... L4	1/H5 ... L4	2/H5 ... L5	2/H5 ... L5	1 <sup>st</sup> (2 <sup>nd</sup> ) BT ... L1	2 <sup>nd</sup> (2 <sup>nd</sup> ) BT ... L6	
34.	6	6	6	6	5	5	4 <sup>th</sup> (5 <sup>th</sup> ) BT L1	4 <sup>th</sup> (5 <sup>th</sup> ) BT L1	2 <sup>nd</sup> (5 <sup>th</sup> ) BT L6	2 <sup>nd</sup> (5 <sup>th</sup> ) BT L6	2 <sup>nd</sup> (2 <sup>nd</sup> ) BT ... L6		
35.	6	6	6	6	6	5							
36.	6	6	6	6	6	6							
							<b>Plan F1 - SF2</b>		<b>Plan F2 - SF2</b>		<b>FINAL B</b>		
							2/H1 ... L4	1/H2 ... L3	4/H1 ... L6	2/H2 ... L4	3 <sup>rd</sup> (2 <sup>nd</sup> ) BT ... L3	4 <sup>th</sup> (2 <sup>nd</sup> ) BT ... L4	3/SF1 ... L1
							4/H3 ... L1	3/H4 ... L5	1/H3 ... L3	3/H4 ... L5	3/SF2 ... L6	3/SF3 ... L5	3/SF4 ... L2
							2/H5 ... L2	3 <sup>rd</sup> (5 <sup>th</sup> ) BT L6	3/H5 ... L2	4 <sup>th</sup> (5 <sup>th</sup> ) BT L1			
							<b>Plan F1 - SF3</b>		<b>Plan F2 - SF3</b>		<b>FINAL C</b>		
							3/H1 ... L2	2/H2 ... L4	1/H1 ... L3	3/H2 ... L2	4/SF1 ... L4	4/SF2 ... L3	4/SF3 ... L2
							1/H3 ... L3	4/H4 ... L6	2/H3 ... L4	4/H4 ... L5	4/SF4 ... L5	1 <sup>st</sup> (5 <sup>th</sup> ) BT ... L1	2 <sup>nd</sup> (5 <sup>th</sup> ) BT . L6
							3/H5 ... L5	2 <sup>nd</sup> (5 <sup>th</sup> ) BT L1	4/H5 ... L1	1 <sup>st</sup> (5 <sup>th</sup> ) BT L6			
							<b>Plan F1 - SF4</b>		<b>Plan F2 - SF4</b>				
							4/H1 ... L5	3/H2 ... L2	2/H1 ... L5	4/H2 ... L6			
							2/H3 ... L4	1/H4 ... L3	3/H3 ... L2	1/H4 ... L3			
							4/H5 ... L1	1 <sup>st</sup> (5 <sup>th</sup> ) BT L6	1/H5 ... L4	3 <sup>rd</sup> (5 <sup>th</sup> ) BT L1			
1 <sup>st</sup> -4 <sup>th</sup> to SF rest out							1 <sup>st</sup> + 2 x 2 <sup>nd</sup> BT to Final A 2 x 2 <sup>nd</sup> + 4 x 3 <sup>rd</sup> to Final B 4 x 4 <sup>th</sup> + 2 x 5 <sup>th</sup> BT to Final C rest out						

## APPENDIX 2 - TECHNICAL SPECIFICATION SHEET OF THE DRAGON BOATS

### I - 8-seater boat

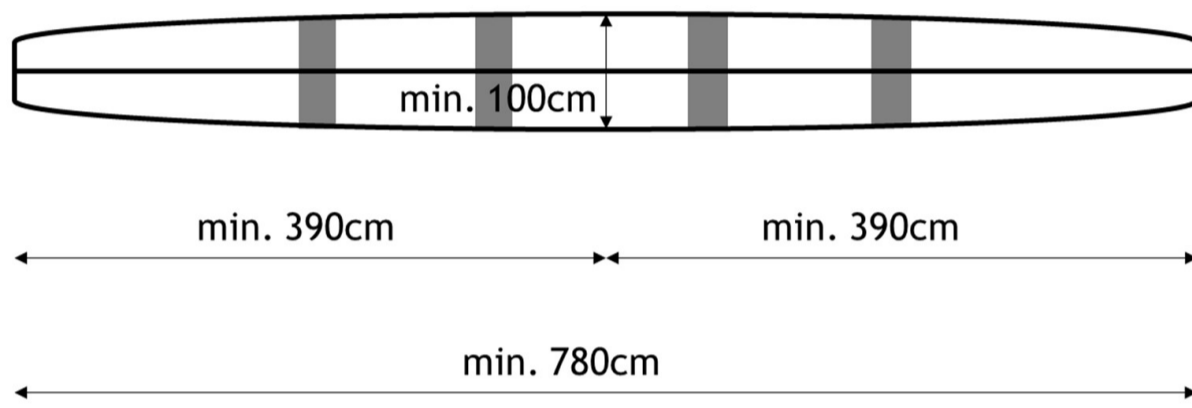
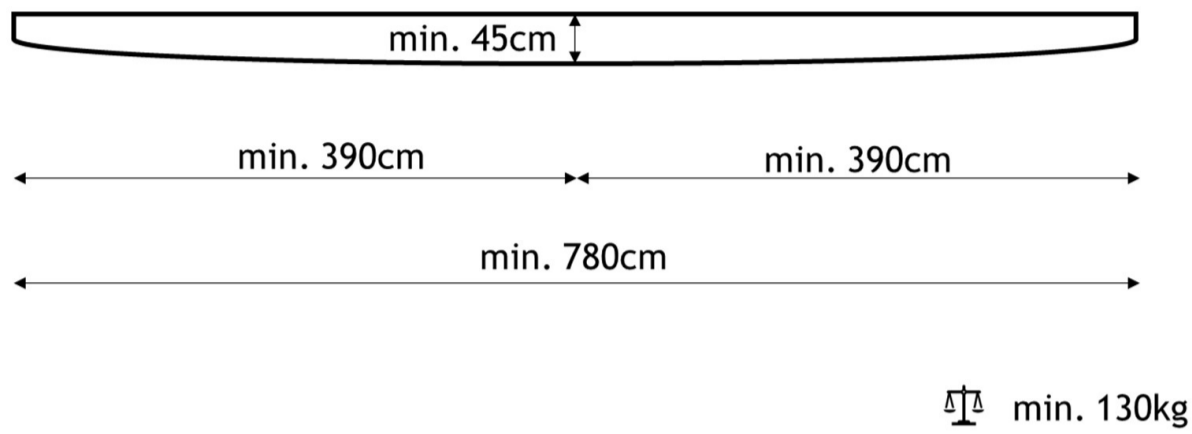

### II - 10-seater boat

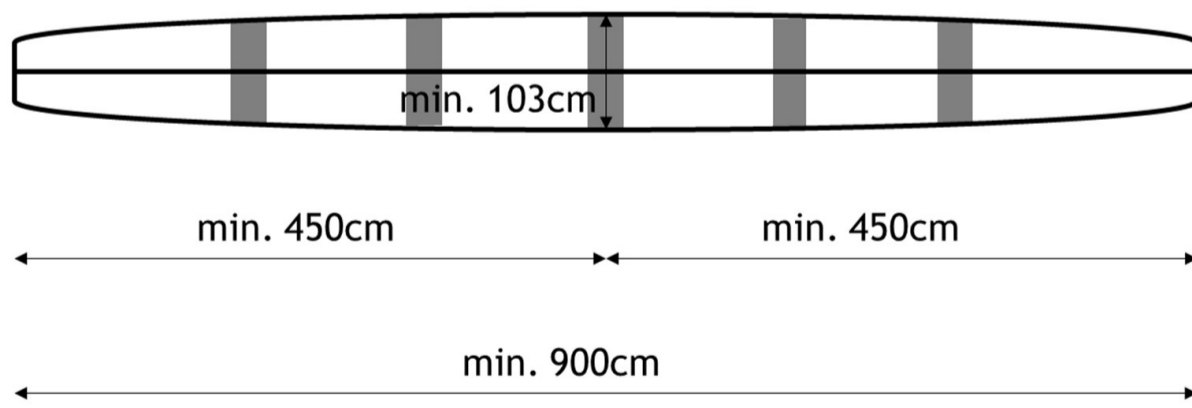
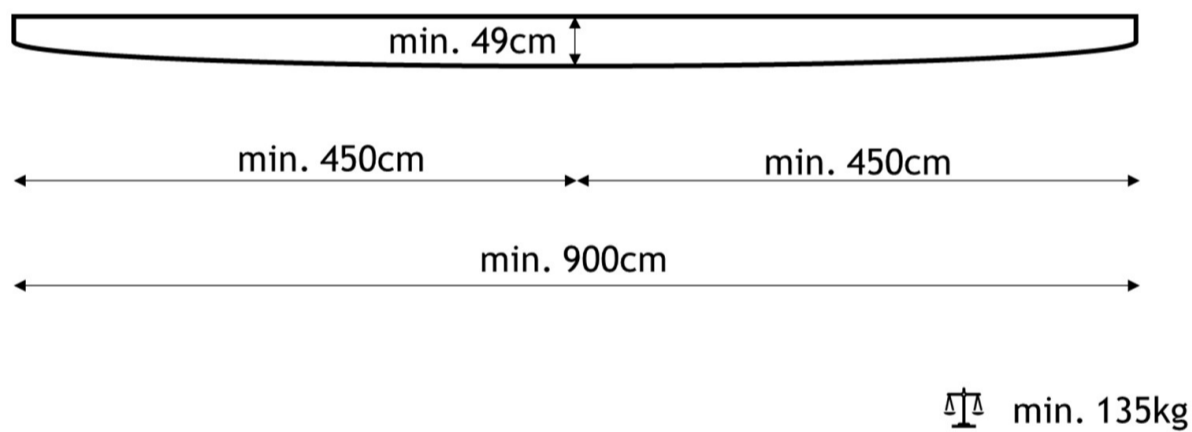

Deleted:

10-seater boat

Deleted: 2023

### III - 20-seater boat

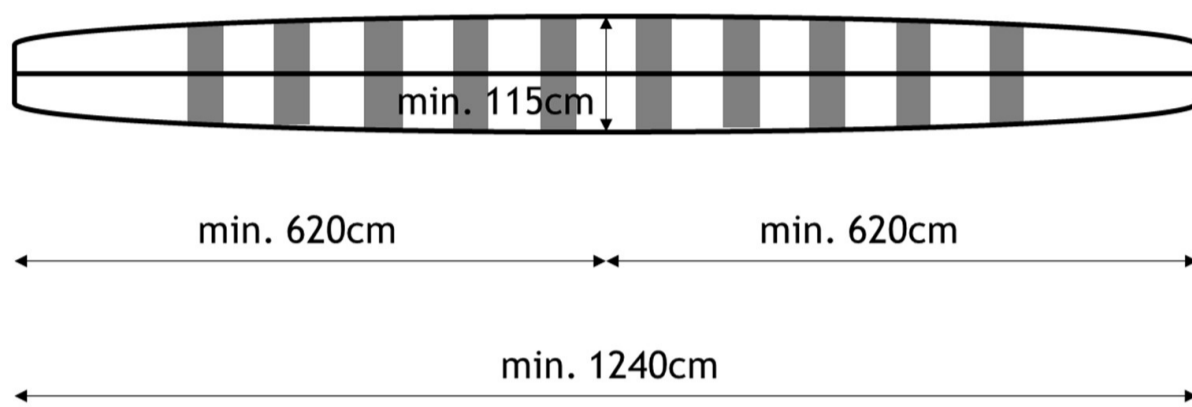
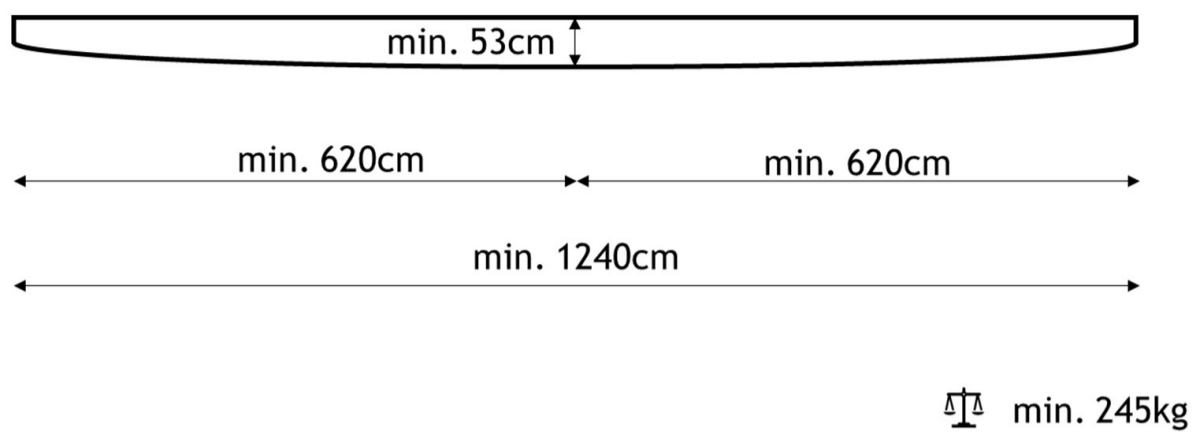

Formatted: Justified, Space Before: 12 pt

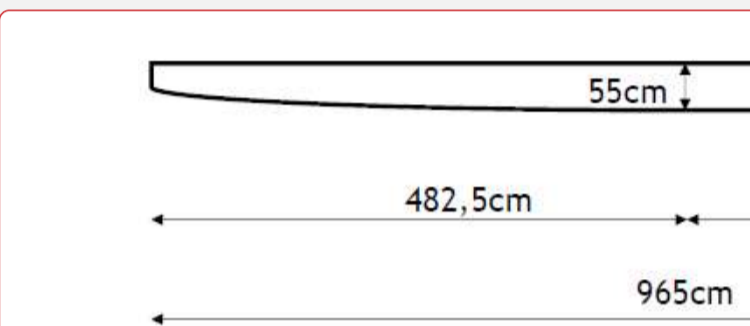

Deleted:

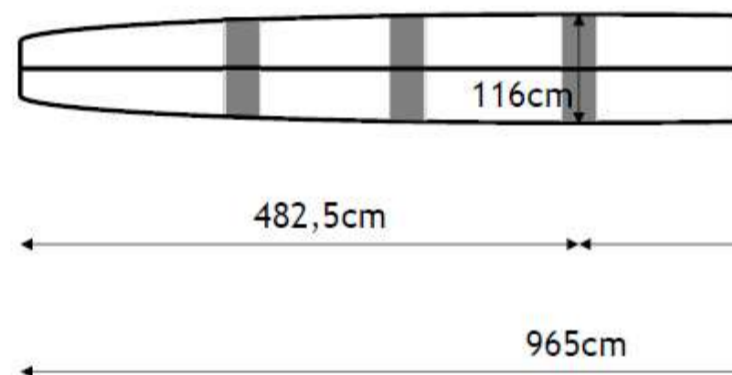

20-seater boat

Deleted:

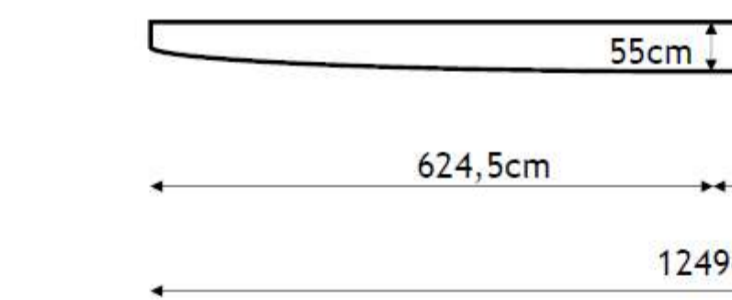

Deleted:

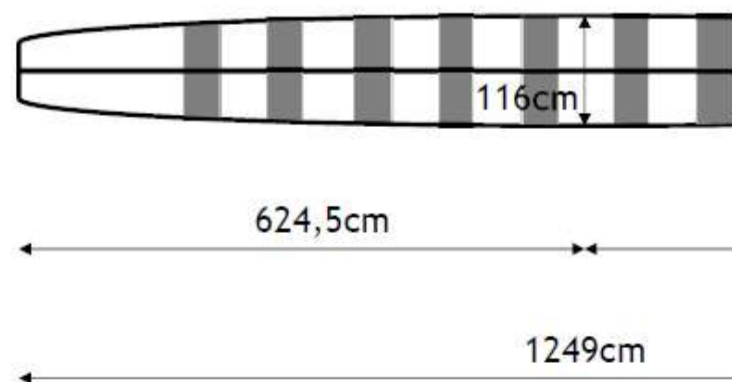

Deleted: 2023

APPENDIX 3 - TECHNICAL SPECIFICATION SHEET FOR THE PADDLE

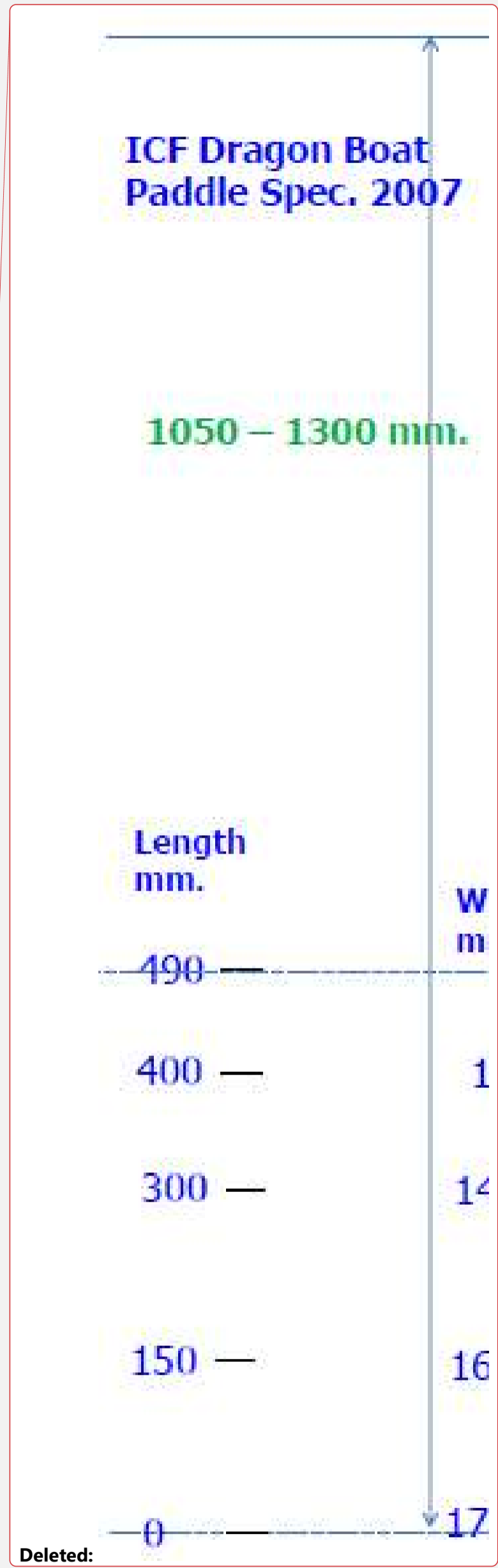
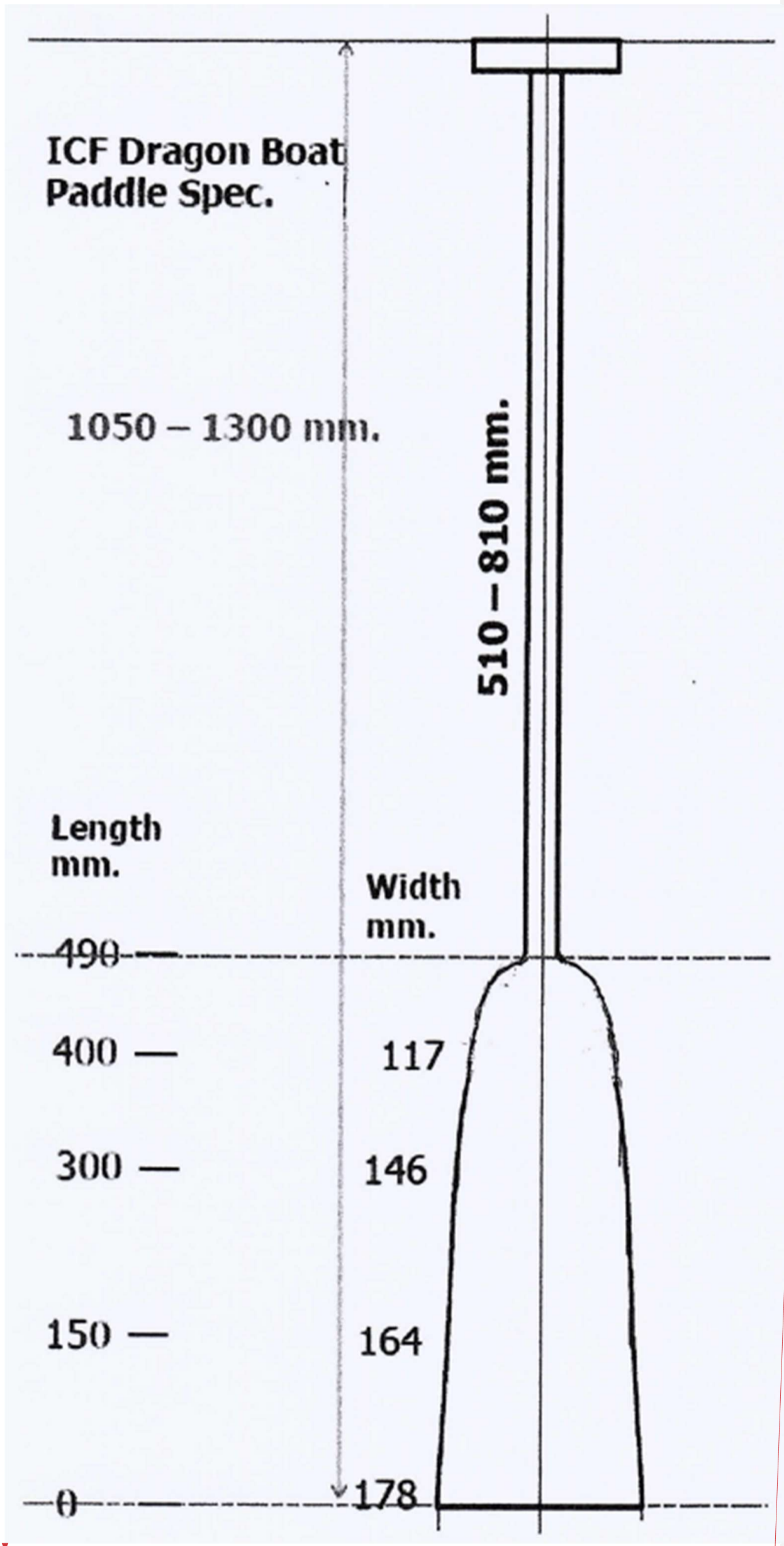

Deleted:

Deleted: 2023

# APPENDIX 4 - STARTING POSITION OF THE BOATS FOR 2000 METERS PURSUIT RACE

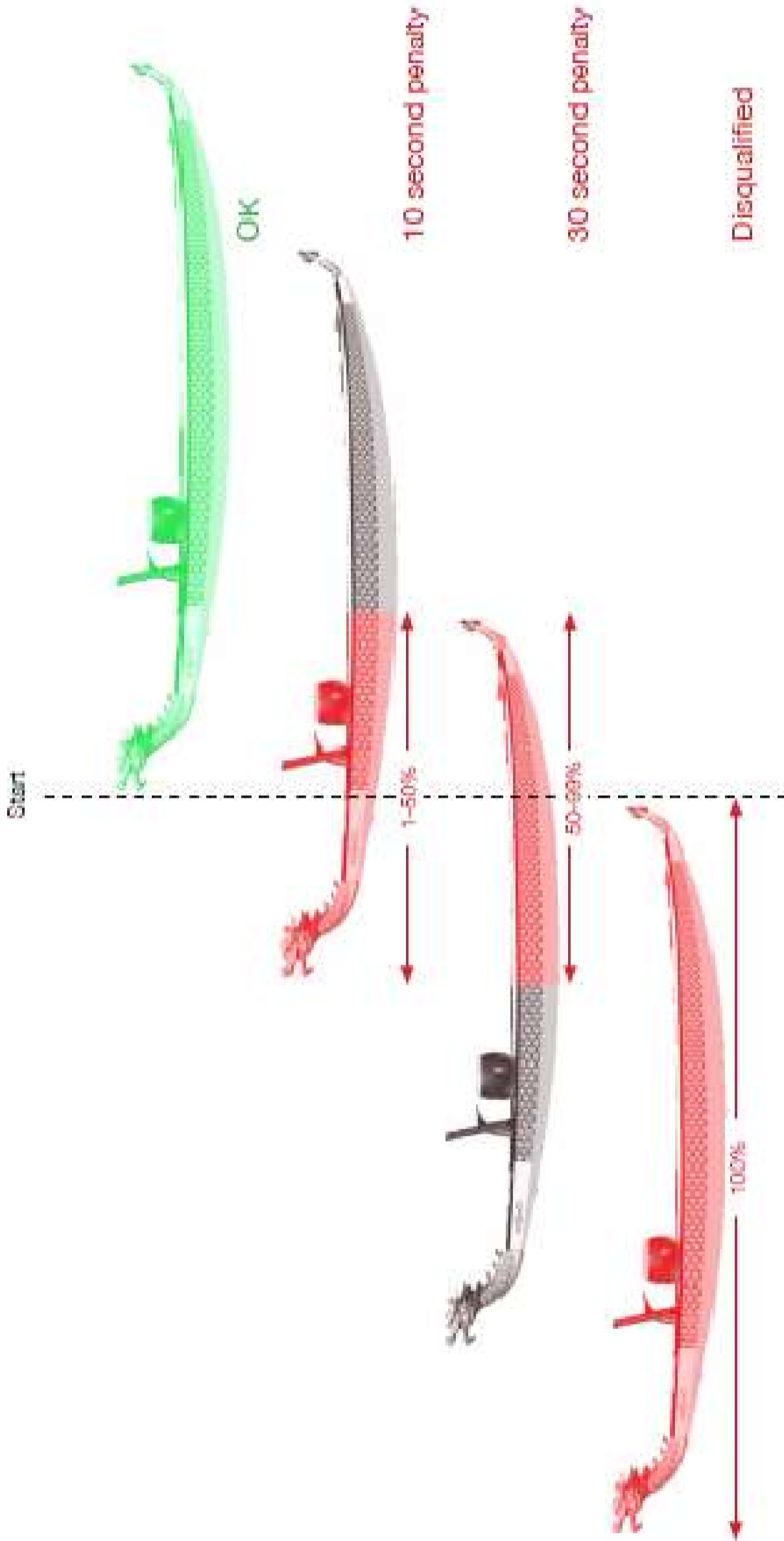

# APPENDIX 5 - BOATS HAVING THE RIGHT TO ENTER INTO THE TURN FIRST

